

Liebert® Xtreme Density™
System Design Manual



TABLE OF CONTENTS

1.0	SYSTEM DESCRIPTION	1
1.1	European Union Fluorinated Greenhouse Gas Requirements	2
1.2	Direct and Indirect System Configurations	2
1.3	Liebert XDO—Overhead Cooling Module	3
1.4	Liebert XDV—Vertical, Above-Cabinet Cooling Module	4
1.5	Liebert XDH—Horizontal Cooling Module	5
1.6	Liebert XDCF	6
1.7	Liebert XDA—Air Flow Enhancer	7
1.8	Liebert XDP—Pumping Unit	8
1.8.1	Liebert XDP Minimum Load	8
1.9	Liebert XDC—Refrigerant Chiller	9
1.9.1	Liebert XDC Minimum Load	9
1.10	Liebert XD Piping	10
1.10.1	Liebert XD Field Piping	10
2.0	STARTING A NEW EQUIPMENT COOLING PROJECT	11
2.1	Determining Cooling Equipment Needs	11
2.2	Implementing a Hot-Aisle/Cold Aisle Design	12
3.0	DESIGNING A LIEBERT XD SOLUTION	13
3.1	Determine Cooling Requirements and Select Liebert XD System	13
3.2	Calculate the Heat Load to be Handled by Liebert XD System	13
3.3	Selecting Liebert XD Cooling Modules	14
3.4	Airflow Requirements for Liebert XD Solutions	14
3.5	Configuring a Liebert XD System	14
3.5.1	Number of Modules Supported by a Liebert XDP or Liebert XDC	14
3.6	Liebert XDO Placement	15
3.6.1	Determining Spacing of Liebert XDOs in an Aisle	15
3.6.2	Determining Vertical Placement of Liebert XDOs Above the Cold Aisle	16
3.7	Liebert XDV Unit Placement	17
3.8	Liebert XDCF Placement	18
3.9	Liebert XDH Placement	19
3.10	Liebert XDP/Liebert XDC Placement	19
3.11	Examples of Expansion and Interlaced Connection of Liebert XD Cooling Modules	20
3.12	Liebert XD Refrigerant	22
3.13	Liebert XD Piping System Design	22
3.14	Liebert XD Piping Slope	24
3.15	Bypass Flow Controllers	24
3.16	Determining Refrigerant Volume	26
3.16.1	Liebert XDP/Liebert XDC Pumped R-134a Circuit Volume	26
3.16.2	Calculating Refrigerant Charge—Example	28
3.17	Liebert XDC DX R-407c Circuit Volume—Air Cooled Units	28
3.18	Chilled Water Piping	29
3.19	Electrical	29

3.20	Display Panel and Remote Temperature/Humidity Sensor Locations	29
4.0	LIEBERT XD COOLING MODULES—LIEBERT XDO, LIEBERT XDV, LIEBERT XDH AND LIEBERT XDCF	30
4.1	Liebert XDO Standard Features	30
4.1.1	Optional Features Liebert XDO.	30
4.2	Liebert XDV Standard Features	33
4.2.1	Optional Features—Liebert XDV	34
4.3	Liebert XDCF Standard Features	40
4.4	Liebert XDCF Mechanical Considerations	41
4.5	Liebert XDCF Installation Considerations.	42
4.6	Liebert XDCF Piping Connection Methods and Points	42
4.6.1	Header System	43
4.7	Liebert XDH Standard Features	43
4.7.1	Optional Features—Liebert XDH	43
4.7.2	Piping Connections to Liebert XDP or Liebert XDC	45
4.8	Liebert XD Flex Pipe Kit	46
4.9	Liebert XD Piping Dimensions and Features.	47
4.9.1	Piping Installation Method prefabricated headers.	47
4.10	Liebert XDP Standard Features	51
4.11	Liebert XDC Standard Features	55
4.11.1	Liebert XDC Optional Features.	55
5.0	SPECIFICATIONS	64

FIGURES

Figure 1	Pressure enthalpy diagram - refrigerant.	1
Figure 2	Direct system configuration—hydraulic system diagram	2
Figure 3	Indirect system configuration—hydraulic system diagram	2
Figure 4	Suspended Liebert XDO modules in hot aisle-cold aisle arrangement	3
Figure 5	Top-mounted Liebert XDV modules with fixed piping in hot aisle-cold aisle arrangement.	4
Figure 6	Top-mounted Liebert XDV modules with flexible piping in hot aisle-cold aisle arrangement.	4
Figure 7	Liebert XDH—horizontal cooling module in hot aisle-cold aisle arrangement	5
Figure 8	Liebert XDCF units on BladeFrame EX cabinets.	6
Figure 9	Liebert XDA—air flow enhancer—on Liebert Foundation enclosure	7
Figure 10	Liebert XDP pumping unit.	8
Figure 11	Liebert XD Chiller unit.	9
Figure 12	Liebert XD connection port kit.	10
Figure 13	Hot aisle-cold aisle arrangement with under-floor source	12
Figure 14	Liebert XDO placement over cold aisle	15
Figure 15	Liebert XDO spacing—horizontal and vertical	16
Figure 16	Positioning Liebert XDV on top of cabinet	17
Figure 17	Liebert XDCF unit mounting locations	18
Figure 18	Liebert XDH placement	19
Figure 19	Liebert XDV units mounted on racks emitting 3kW of heat, top view	20
Figure 20	Liebert XDV units mounted on racks emitting 5kW of heat, top view	20
Figure 21	Liebert XDV units mounted on racks emitting 8kW of heat top view	21
Figure 22	Liebert XDV units mounted on racks emitting 16kW of heat top view	21
Figure 23	Piping for Liebert XDP/Liebert XDC used with Liebert XD cooling units	23

Figure 24	Hydraulic diagram	24
Figure 25	Bypass flow controller details, dimensions	25
Figure 26	Bypass flow controller arrangement	25
Figure 27	Bypass flow controller piping	25
Figure 28	Dimensional data—Liebert XDO hard-piped units	31
Figure 29	Dimensional data—Liebert XDO with pre-charged option	31
Figure 30	Liebert XDO internal mounting location.	32
Figure 31	Liebert XDO top and front electrical access points	33
Figure 32	Liebert XDV dimensions	34
Figure 33	Liebert XDV dimensions with one-shot connection	35
Figure 34	Liebert XDV electrical connections for CE approved units	36
Figure 35	Liebert XDV electrical connections for CSA-approved units	37
Figure 36	Suspending single Liebert XDV from Unistruts	38
Figure 37	Suspending single Liebert XDV from the roof structure	38
Figure 38	Alternative mounting methods—mounting multiple Liebert XDV units	39
Figure 39	Liebert XDCF hydraulic diagram	40
Figure 40	Overall dimensions	41
Figure 41	Liebert XDCF unit mounting locations	42
Figure 42	Liebert XDCF supply and return piping access points.	43
Figure 43	Liebert XDH dimensions	44
Figure 44	Supply and return piping connections.	44
Figure 45	Hard-pipe connection diagram for Liebert XDV, Liebert XDO and Liebert XDH cooling modules	45
Figure 46	Two-port prefabricated piping for Liebert XD cooling modules	47
Figure 47	Four-port prefabricated piping for Liebert XD cooling modules	48
Figure 48	Five-port prefabricated piping for Liebert XD cooling modules	49
Figure 49	Ten-port prefabricated piping for Liebert XD cooling modules	50
Figure 50	Liebert XDP dimensions.	51
Figure 51	Liebert XDP piping access points and external features	52
Figure 52	Front view of Liebert XDP and electrical enclosure	53
Figure 53	Liebert XDP electrical enclosure knockout locations for field wiring	53
Figure 54	Liebert XDP 60Hz high voltage connections	54
Figure 55	Liebert XDP 50Hz high voltage connections	54
Figure 56	Liebert XDC dimensional data.	55
Figure 57	Liebert XDC piping locations	56
Figure 58	Positioning a water/glycol Liebert XDC for placement on a floor stand	57
Figure 59	Piping locations—floor stand and valve assembly	58
Figure 60	Front view of Liebert XDC and electrical enclosures	59
Figure 61	Liebert XDC electrical enclosure knockout locations for field wiring	59
Figure 62	Liebert XDC high voltage connections—primary disconnect switch, 60Hz models	60
Figure 63	Liebert XDC high voltage connections—primary disconnect switch, 50Hz models	60
Figure 64	Liebert XDC high voltage connections—secondary disconnect switch, 60Hz models.	61
Figure 65	Liebert XDC high voltage connections—secondary disconnect switch, 50Hz models.	61
Figure 66	Liebert XDC heat rejection electrical connection points.	62
Figure 67	Liebert XDC electrical enclosure knockout locations for Extra Low Voltage connections	62
Figure 68	Liebert XDC Extra Low Voltage field connections points	63

TABLES

Table 1	Liebert XD field-installed port kits header connection size	10
Table 2	Maximum and minimum modules supported by a Liebert XDP or Liebert XDC	14
Table 3	Calculating quantity and spacing of Liebert XDO modules (example below is Liebert XDO20)	15
Table 4	Determine required number of Liebert XDV modules (example below is Liebert XDV10)	17
Table 5	Supply, return pipe sizes for refrigerant loop	23
Table 6	Bypass flow controllers for Liebert XDC- or Liebert XDP-based systems	24
Table 7	System R-134a charge for a Liebert XDP/Liebert XDC with any model Liebert XDH/ Liebert XDO/Liebert XDV/Liebert XDCF	26
Table 8	System refrigerant charge for the supply and return mains	26
Table 9	R-134a refrigerant charge for hard-piped connector lines to and from any model Liebert XDH/Liebert XDO/Liebert XDV/Liebert XDCF	26
Table 10	R-134a refrigerant charge for Flex Pipe connector lines to and from any model Liebert XDO/Liebert XDH/Liebert XDV/Liebert XDCF	27
Table 11	Calculating refrigerant charge—example	28
Table 12	Worksheet to calculate refrigerant charge	28
Table 13	Indoor unit refrigerant charge—R-407c	28
Table 14	Air cooled systems - liquid line charge - R-407c refrigerant per 100 ft (30 m) of Type "L" copper tube	29
Table 15	Indoor water/glycol cooled module – R-407c refrigerant charge	29
Table 16	Outdoor condenser charge—R-407c	29
Table 17	Liebert XD Flex Pipe assemblies, supply and return	46
Table 18	Two-port prefabricated piping legend	47
Table 19	Four-port prefabricated piping legend	48
Table 20	Five-port prefabricated piping legend	49
Table 21	Ten-port prefabricated piping legend	50
Table 22	Liebert XDP dimensions	51
Table 23	Unit piping outlet connection sizes, inches, OD Cu	52
Table 24	Liebert XD Chiller dimensions, weight	55
Table 25	Liebert XD Chiller piping connection sizes	56
Table 26	Liebert XDC Water/Glycol Piping Connection Sizes	57
Table 27	Liebert XDC160 specifications	64
Table 28	Floor stand specifications—water-cooled Liebert XDC	65
Table 29	Floor stand specifications—Liebert XDC with 40% propylene glycol	65
Table 30	Floor stand specifications—Liebert XDC with 40% ethylene glycol	66
Table 31	Liebert XDP160 specifications	67
Table 32	Liebert XDO16 specifications	68
Table 33	Liebert XDO20 specifications	69
Table 34	Liebert XDO20 dimensions—domestic and export	70
Table 35	Liebert XDO16 dimensions—domestic and export	70
Table 36	Liebert XDV8 specifications	71
Table 37	Liebert XDV10 specifications	72
Table 38	Liebert XDV8 dimensions—domestic and export	73
Table 39	Liebert XDV10 dimensions—domestic and export	73
Table 40	Liebert XDCF specifications	73
Table 41	Liebert XDH specifications	74

1.0 SYSTEM DESCRIPTION

The Liebert XD™ family of cooling units delivers efficient, sensible cooling to high-heat environments. Liebert XD systems are designed to cool computer racks and hot zones in a data center or computer room without taking up expensive floor space for cooling components.

The Liebert XD family includes:

- **Liebert XDC**—Liebert XD Chiller; cools and pumps refrigerant to cooling modules
- **Liebert XDP**—Liebert XD Pumping unit; pumps refrigerant to cooling modules
- **Liebert XDA**—mounts on the rear of the equipment cabinet
- **Liebert XD CF**—mounts on the rear of an Egenera BladeFrame EX cabinet
- **Liebert XD H**—Liebert XD Horizontal row cooler; integrated into hot aisle-cool aisle room layout
- **Liebert XD O**—Liebert XD Overhead unit, suspended from the ceiling structure
- **Liebert XD V**—Liebert XD Vertical unit; mounted on top of the equipment cabinet or suspended from the ceiling structure

Systems combining Liebert XDO and Liebert XDV units can remove more than 20 kW (5.7 tons) of heat per cabinet. A set of Liebert XD CF modules also can remove 20kW (5.7 tons) of heat from an Egenera BladeFrame EX cabinet. A system with Liebert XD H units can remove more than 30kW (8.5tons) of heat per rack.

For minimum Liebert XDP and Liebert XDC load recommendations, see **1.8.1 - Liebert XDP Minimum Load**; **1.9.1 - Liebert XDC Minimum Load**; and **Tables 27** and **31**.

The Liebert XD system also performs at high efficiency rates. Properly spaced cooling modules and the Liebert XD system's fluid phase change technology, combine to reduce a Liebert XD system's energy consumption to at least 27 percent less than a traditional cooling system.

The Liebert XD family maintains this energy efficiency by employing the heat absorption properties of a liquid (pumped refrigerant) through a phase change. Refrigerant is pumped as a liquid, becomes a gas within the heat exchangers of the cooling modules (either the Liebert XD CF, Liebert XD H, Liebert XD O or Liebert XD V) and then is returned to either the Liebert XDP or Liebert XDC where it condenses to a liquid. This eliminates the compression cycle required by traditional systems. And, if a leak were to occur, the environmentally friendly refrigerant would escape as a gas, causing no harm to critical equipment (see **Figure 1**). Because no compressor is used in the circuit, no oil is needed.

Figure 1 Pressure enthalpy diagram - refrigerant

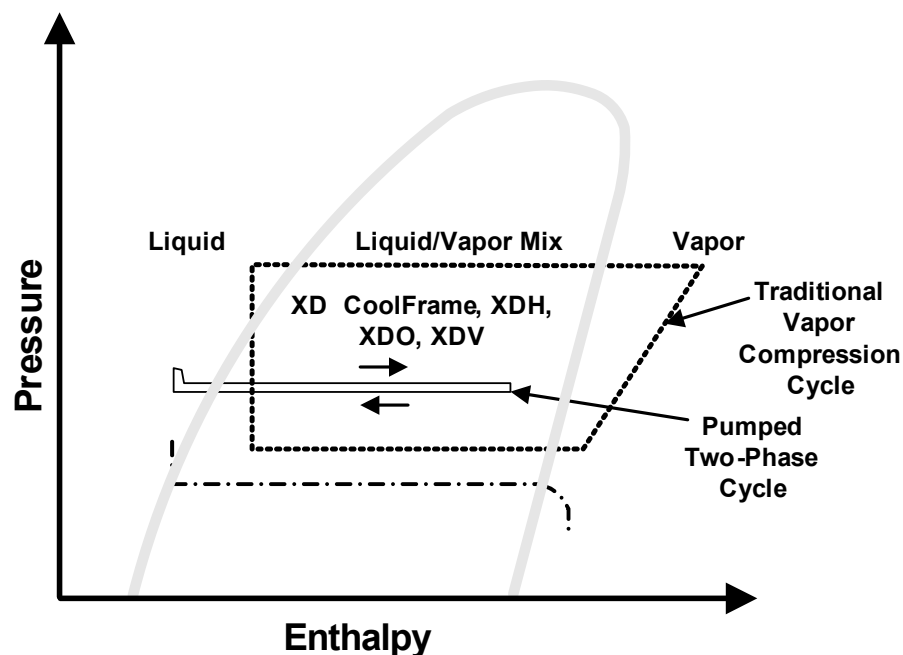

1.1 European Union Fluorinated Greenhouse Gas Requirements

Stationary air conditioning, refrigeration, heat pump equipments and stationary fire protection systems in the European Community market and operating with fluorinated greenhouse gases (f-gas), such as R407C, R134a, R410A, must comply with the F-Gas Regulation: (EC) No. 842/2006 (F-gas). The regulation prohibits, among other actions, venting fluorinated greenhouse gases to the atmosphere.

The F-Gas Regulation requires operators to use all measures that are technically feasible and do not entail disproportionate cost to prevent leakage of these gases, to test for leakage regularly and to recover f-gas before disposing of equipment, as well as during service and maintenance.

Refer to the full regulation for additional details.

1.2 Direct and Indirect System Configurations

Liebert XD systems are available in **Direct** and **Indirect** configurations—differentiated essentially by the method of heat rejection (see **Figures 2** and **3**). The indirect system uses a pumping unit connected to a building chilled water system to control and circulate the refrigerant. In the direct system, the pumping functions are incorporated in the chiller, which must be connected to a separate heat rejection system.

Figure 2 Direct system configuration—hydraulic system diagram

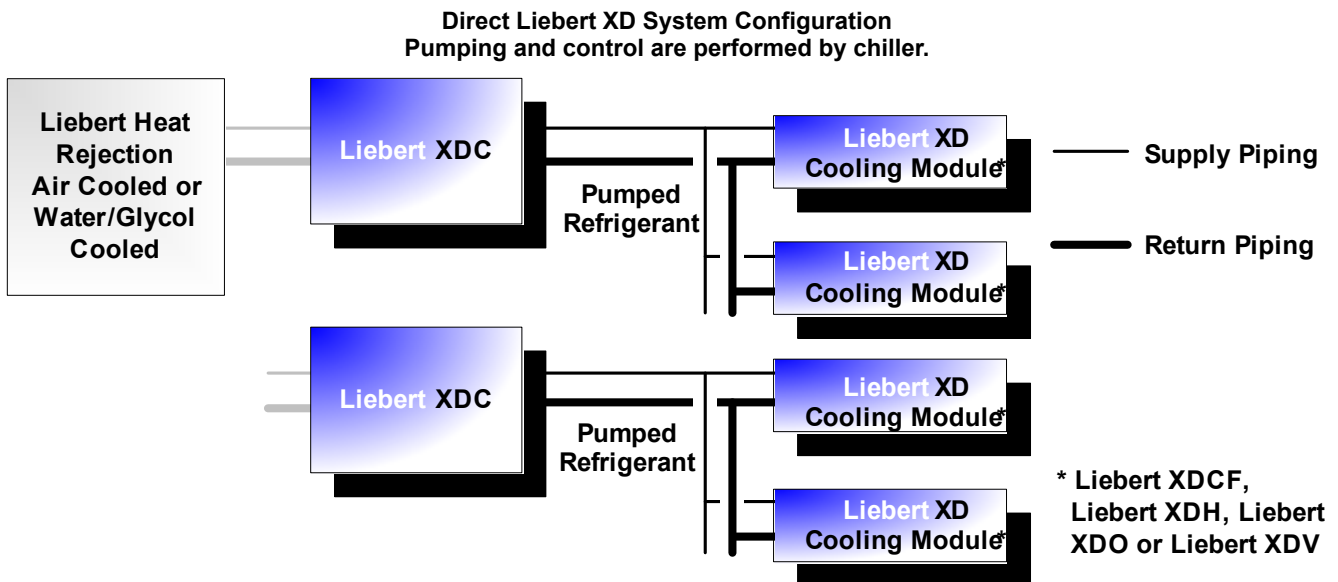
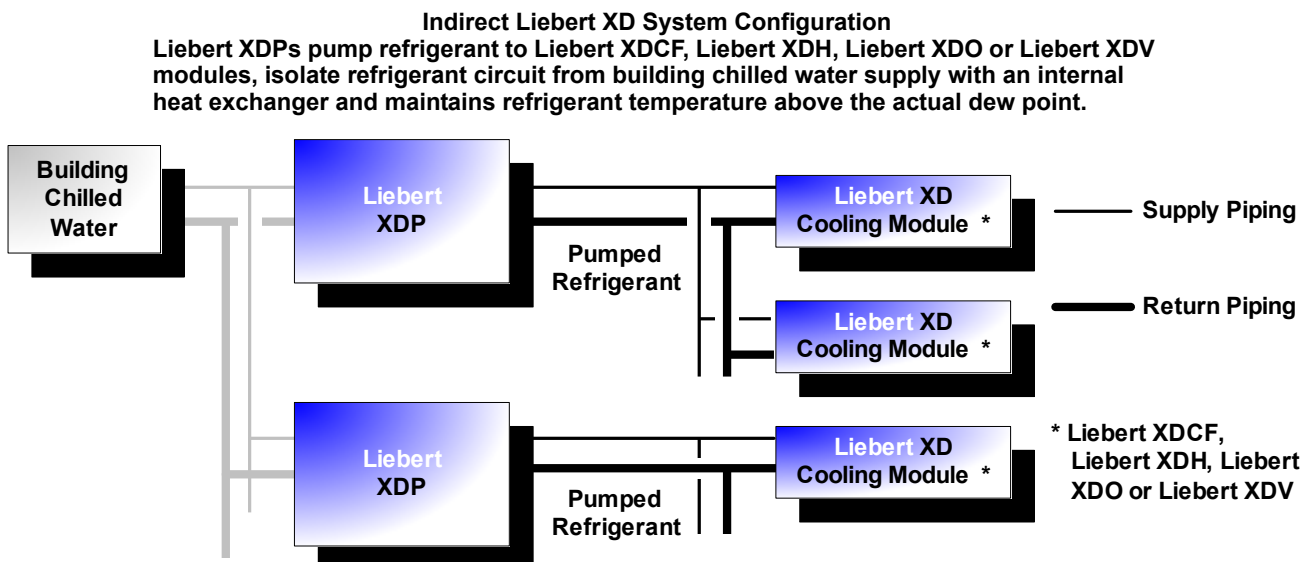

Figure 3 Indirect system configuration—hydraulic system diagram



1.3 Liebert XDO—Overhead Cooling Module

The Liebert XDO ceiling-mounted cooling module draws in hot air rising from densely populated cabinets, passes it over the Liebert XDO's coils and exhausts cooled air downward into the cold aisle. The unit is available with optional, flexible metal pipes with quick-connect couplings at each end for easy connection to the refrigerant distribution pipes.

Figure 4 Suspended Liebert XDO modules in hot aisle-cold aisle arrangement

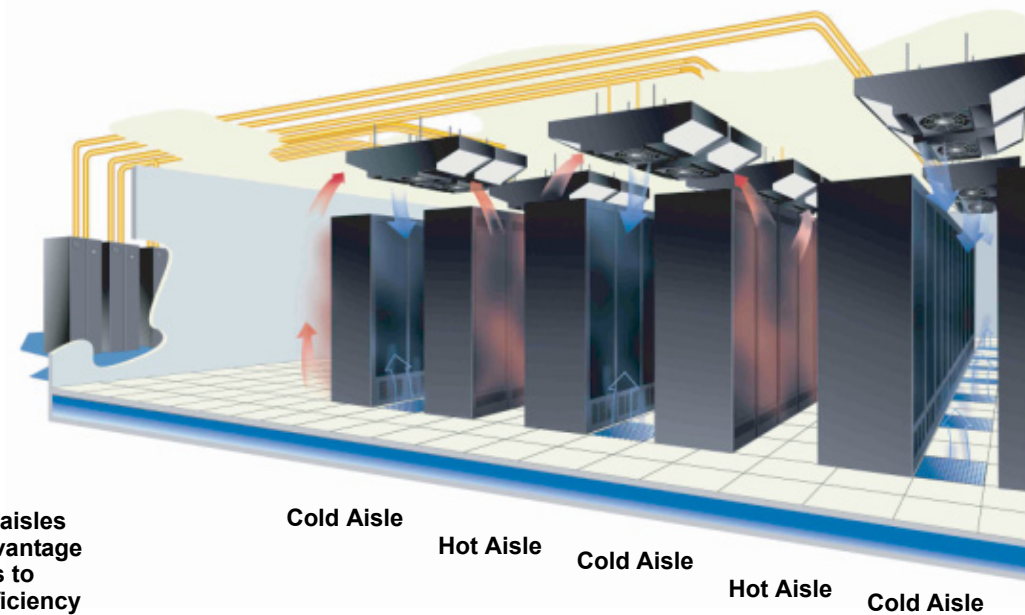

1.4 Liebert XDV—Vertical, Above-Cabinet Cooling Module

The Liebert XDV is installed on top of or above a rack enclosure. It is available with optional flexible metal pipes with automatic shutoff with quick-connect couplings at the ends for easy connection to the refrigerant distribution pipes. The Liebert XDV may be set up in either of two ways:

- The Liebert XDV can take hot air directly from an equipment enclosure, cool the air and discharge it downward into the cold aisle.
- OR*
- The Liebert XDV can draw hot air from the room, cool the air and discharge the cool air downward into the cold aisle.

Figure 5 Top-mounted Liebert XDV modules with fixed piping in hot aisle-cold aisle arrangement

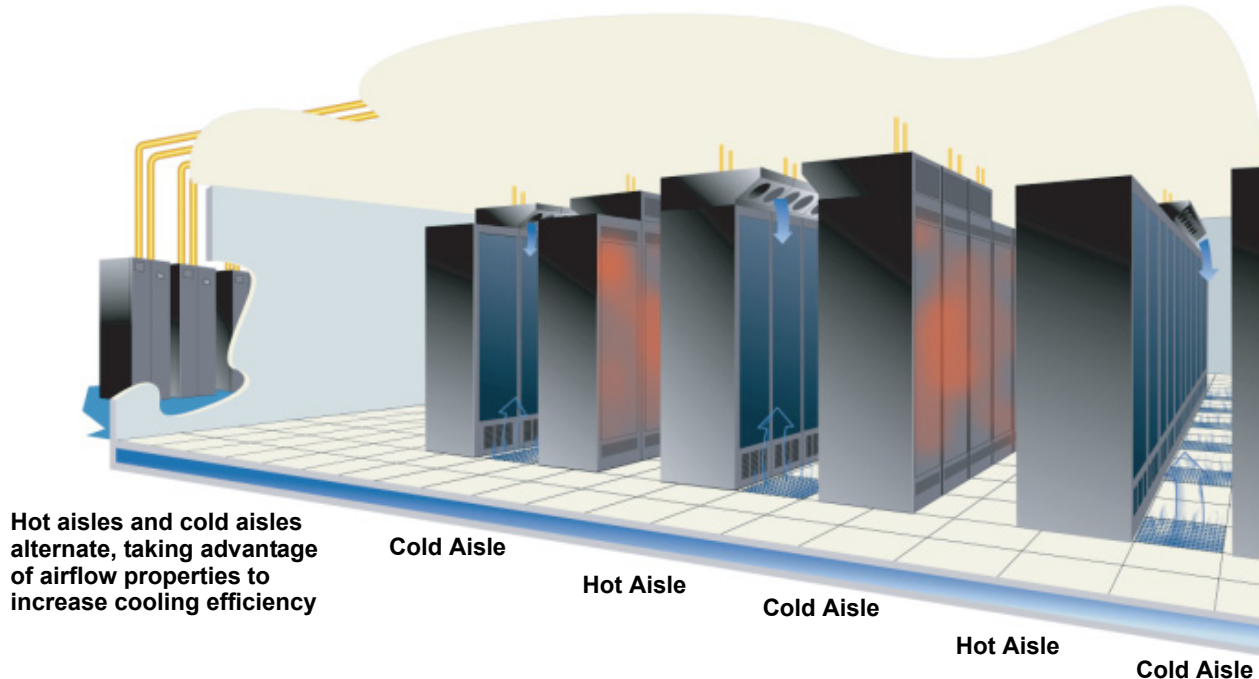
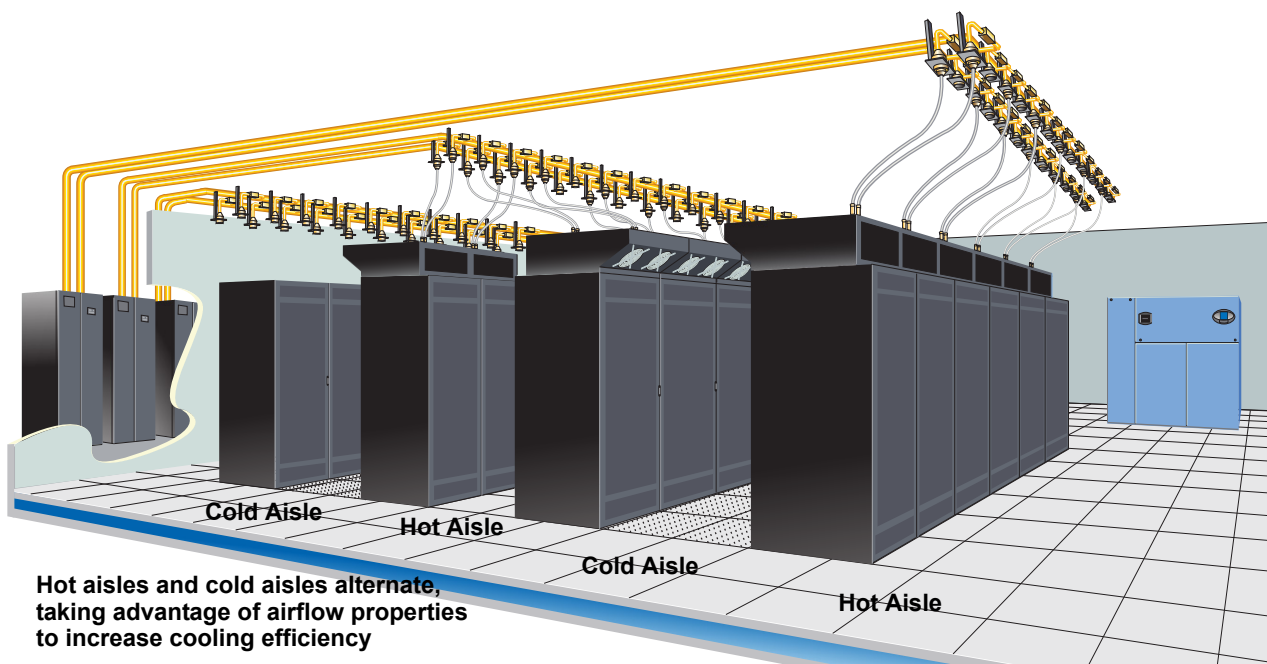

Figure 6 Top-mounted Liebert XDV modules with flexible piping in hot aisle-cold aisle arrangement



1.5 Liebert XDH—Horizontal Cooling Module

The Liebert XDH cooling module is designed to be placed within a row of server enclosures in a hot aisle-cold aisle arrangement. The Liebert XDH has dual refrigeration circuits and is available in a half-rack-width unit. The Liebert XDH is intended for use with a Liebert XD pumped refrigerant cooling system, supplied by either a Liebert XDP or Liebert XDC.

The Liebert XDH is available with optional, flexible metal pipes with quick-connect couplings at each end for easy connection to the refrigerant distribution pipes.

Figure 7 Liebert XDH—horizontal cooling module in hot aisle-cold aisle arrangement



1.6 Liebert XDCF

The Liebert XDCF is a self-contained module designed to cool Egenera's BladeFrame EX cabinets and equipment without exhausting heat into the room. Two modules (top and bottom) may be mounted on the rear of a BladeFrame cabinet. CF modules consist of a sheet-metal frame, coil and filter dryer. It has no moving parts and needs no electricity.

The unit is available with optional, flexible metal pipes with quick-connect couplings at each end for easy connection to the refrigerant distribution pipes.

Figure 8 Liebert XDCF units on BladeFrame EX cabinets

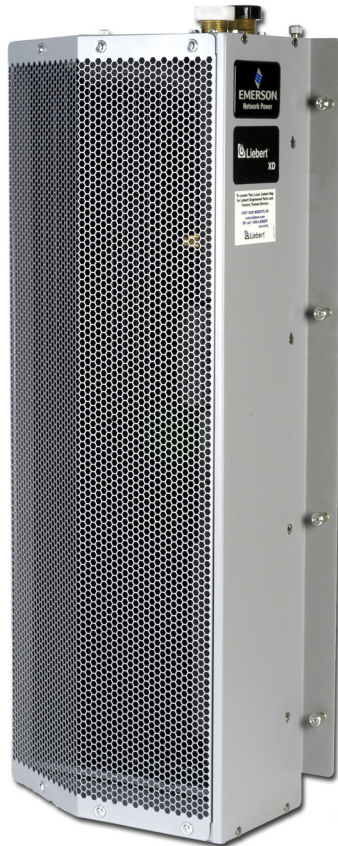

1.7 Liebert XDA—Air Flow Enhancer

The Liebert XDA is a fan unit that boosts the airflow through densely populated enclosures, removing hot spots from within the racks. One or two units can be mounted on the rear of most rack enclosures.

Figure 9 Liebert XDA—air flow enhancer—on Liebert Foundation enclosure



1.8 Liebert XDP—Pumping Unit

The Liebert XDP isolates the building's chilled water circuit from the pumped refrigerant circuit. The Liebert XDP circulates refrigerant to Liebert XDCF, Liebert XDH, Liebert XDO or Liebert XDV modules while preventing condensation by maintaining the refrigerant's temperature above the dew point. The Liebert XDP employs two sets (for redundancy) of remote sensors to determine the temperature and humidity in the air and instantly adjusts refrigerant supply temperature to compensate for changing conditions.

1.8.1 Liebert XDP Minimum Load

The Liebert XDP's minimum recommended operating load is 20% of system nominal capacity. For example, a Liebert XDP160 60Hz system's minimum load would be 32 kW. Loading below this value can unfavorably affect system operation. Consult factory for any loading below this recommendation.

Figure 10 Liebert XDP pumping unit



1.9 Liebert XDC—Refrigerant Chiller

The Liebert XDC is an indoor chiller that connects directly to the Liebert XD cooling modules and provides refrigerant circulation and control. The Liebert XDC keeps the refrigerant temperature above the dew point and eliminates the need for a separate pumping unit in the direct system configuration. The Liebert XDC employs two sets (for redundancy) of remote sensors to determine the temperature and humidity in the air and instantly adjusts refrigerant supply temperature to compensate for changing conditions.

1.9.1 Liebert XDC Minimum Load

The Liebert XDC's minimum recommended operating load is 40% of system nominal capacity. For example, a Liebert XDC160 60Hz system's minimum load would be 64 kW. Loading below this value can unfavorably affect system operation. Consult factory for any loading below this recommendation.

Figure 11 Liebert XD Chiller unit



1.10 Liebert XD Piping

Liebert XD Piping is prefabricated distribution piping that is installed in anticipation of a growing system. Liebert XD cooling modules are added as required and are quickly made operational with flexible connection piping with threaded couplings. This unique system allows the room cooling capacity to increase to more than 30kW per rack with no additional disruptive piping installation. The flexible connection piping also allows the cooling modules to be re-positioned without interruption in operation.

1.10.1 Liebert XD Field Piping

Flexible Piping Kit

Flex pipe kits are available in lengths of 4, 6, 8 and 10 feet (1.2, 1.8, 2.4 and 3 meters). Connection style to the module end may be straight or 90 degrees with one-shot style couplings or removable couplings. Connection to the prefabricated piping assembly is a threaded coupler. For information on acquiring the correct kit for your installation refer to DPN000780_Rev1, available by calling 1-800-LIEBERT and from your local Emerson Network Power representative.

Prefabricated Headers

Field piping kits are available in several versions

- 10 ft. (3.05m) with five or 10 ports
- 8 ft. (2.44m) with two or four ports

Each version is available in two pipe sizes:

- Supply pipe: 1-1/8"; return pipe: 2-1/8"
- Supply pipe: 1-3/8"; return pipe: 2-5/8"

Each kit contains supply pipe(s) and return pipe(s). Each port has a threaded coupling at the end with automatic shutoff when disconnected. Each port also has a ball valve for manual shutoff. For more information refer to section 4.9 - **Liebert XD Piping Dimensions and Features**.

Liebert XD Connection Port Kit

The connection ports in the Liebert XD Field Piping Kits are available as Liebert XD Connection Port Kit. Each port has a threaded coupling, with automatic shutoff when disconnected, at the end. Each port also has a ball valve for manual shutoff. Each kit contains one supply and one return port. Two kit sizes are available:

- Supply pipe: 1-1/8"; return pipe: 2-1/8"
- Supply pipe: 1-3/8"; return pipe: 2-5/8"

Figure 12 Liebert XD connection port kit

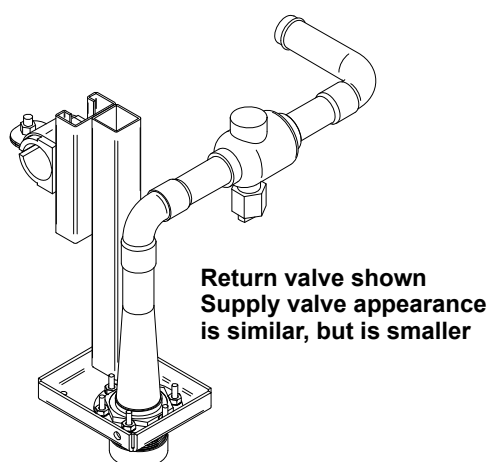

Table 1 Liebert XD field-installed port kits header connection size

Assembly P#	Supply Header Diameter	Return Header Diameter
183169G3	1-1/8"	2-1/8"
183169G4	1-3/8"	2-5/8"

2.0 STARTING A NEW EQUIPMENT COOLING PROJECT

2.1 Determining Cooling Equipment Needs

1. Is adequate space available for a Liebert XD installation? _____
2. Is the hot aisle/cold aisle approach being utilized for this room design or can it be utilized in this room design? _____
3. Is redundant cooling equipment required? _____
4. Are there access considerations for all components (possible rigging problems)? _____
5. What heat load growth is anticipated over the next few years? _____
6. How are the cabinets going to be populated (density of heat generation)? _____
7. What monitoring requirements are desired or needed? _____
8. Who will be involved in this project (stakeholders)? _____
9. Is there existing computer room environmental cooling systems for humidity control and filtration? _____
10. Is the vapor barrier sufficient? _____
11. Is a chilled water system available?
 - a. What is the system's capacity? _____
 - b. What is the system's chilled water supply temperature? _____
 - c. Does the chilled water supply temperature vary during the year or is the temperature constant? _____
12. How much power is available for cooling equipment? _____
13. What is the maximum distance between the Liebert XDP/Liebert XDC unit and the farthest Liebert XD cooling module in the proposed layout? _____
14. If an air cooled Liebert XDC is used – is an area available for the remote condenser? _____

2.2 Implementing a Hot-Aisle/Cold Aisle Design

A best practice is to use rows of equipment racks in an alternating arrangement of cold aisles and hot aisles. This is best accomplished when the layout of the file-server farm area is first being planned, and it is exceedingly more difficult to accomplish when the computer room is already populated with operating hardware.

In the cold aisle, the equipment racks are arranged face to face so the cooling air discharged up through the perforated floor tiles is drawn into the face of the computer hardware and exhausted out the back of the equipment rack onto the adjacent hot aisles.

Hot aisles are literally hot because the objective of the alternating cold and hot aisle design is to separate the source of cooling air from hot air discharge which returns to the computer-room cooling unit. Therefore, no perforated tiles should be placed in the hot aisles, as this would mix hot and cold air and thereby lower the temperature of the air returning to the cooling units, which reduces their usable capacity.

Figure 13 Hot aisle-cold aisle arrangement with under-floor source

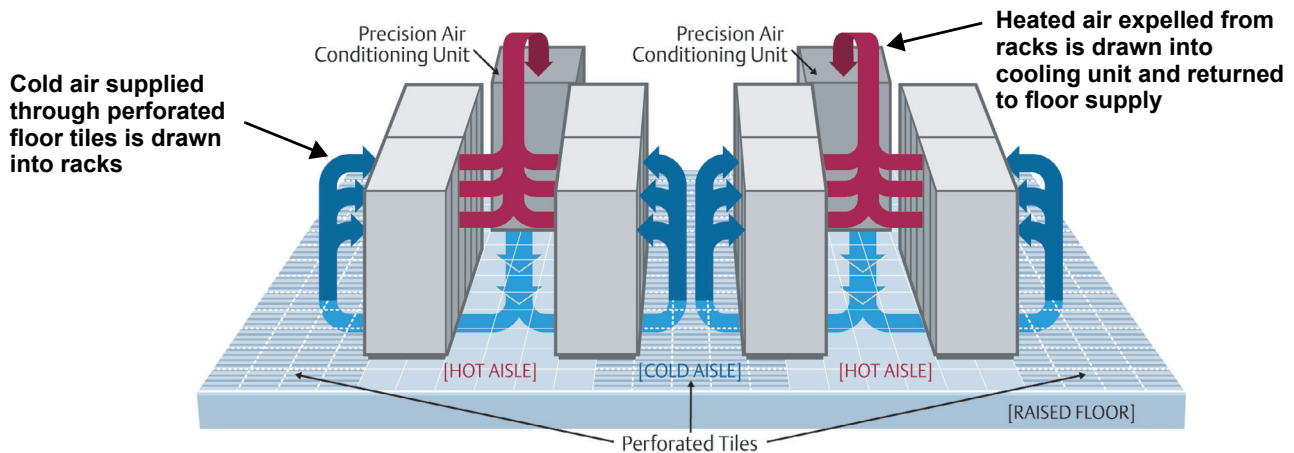

3.0 DESIGNING A LIEBERT XD SOLUTION

Liebert XD systems are intended for use with precision air conditioning equipment, such as the Liebert Deluxe System/3 and Liebert DS. The precision air conditioning equipment is required to control the room's humidity and to filter the air.

The Liebert XD systems provide efficient, highly effective heat removal (sensible cooling only), and provide no dehumidification. The Liebert XD control system maintains the refrigerant temperature just above the dew point of the space to prevent condensation. Since the capacity of the system is limited by the dew point in the space, sufficient dehumidification and an adequate vapor barrier must be provided to maintain the dew point at or below the level necessary to achieve the required capacity.

The Liebert XD system is optimized for hot aisle/cold aisle equipment configurations, the industry's most highly recommended method for dealing with extremely high heat loads.

Refer to the technical data manual of either the Deluxe System/3 (SL-18100) or the Liebert DS (SL-18810) for additional installation and application guidelines that apply to all critical space cooling applications.

3.1 Determine Cooling Requirements and Select Liebert XD System

1. Calculate the total cooling required
2. Determine placement of the Liebert XD units
3. Determine required pipe sizes
4. Calculate the refrigerant volume of the Liebert XD systems
5. Complete design details including, electrical, mounting, piping, etc.

3.2 Calculate the Heat Load to be Handled by Liebert XD System

When designing a cooling solution using the Liebert XD system, the initial steps are similar to those required to cool a conventional critical space. The total heat load must be calculated, including sensible and latent cooling requirements. These should be increased by the reserve capacity needed for pull-down situations where the room temperature must be reduced and to provide for unexpected increases in heat load.



NOTE

Reserve capacity is distinct from redundant capacity in that redundant capacity may or may not be available concurrently with normal operating capacity. Reserve capacity is available concurrently with normal operating capacity.

The next step is to determine how much of the required cooling capacity is to be provided by Liebert Deluxe or Liebert DS units. If the facility is new, typically up to 150 watts per square foot (1500W/m²) of cooling can be obtained from Liebert precision air conditioning units supplying air through a raised floor. In existing facilities, such factors as raised floor height, under-floor obstructions or other limitations may reduce this to less than 50 watts per square foot (500 watts per m²).

Once the total required sensible cooling capacity is known, subtract the sensible cooling portion to be provided by Liebert Deluxe or Liebert DS units. This yields the cooling capacity to be provided by the Liebert XD system.

3.3 Selecting Liebert XD Cooling Modules

The next step is to select the Liebert XD cooling modules to be configured into the solution. Liebert XD modules that use pumped refrigerant can be connected to the same Liebert XDP/Liebert XDC piping circuit. This includes the Liebert XDCF, Liebert XDH, Liebert XDO and Liebert XDV.

Generally, the Liebert XDO is selected for use in new installations or renovations where the unit can be installed on the ceiling or in the overhead space.

The Liebert XDV is designed to permit mounting directly on top of an equipment cabinet, for ease of installation in existing facilities. The Liebert XDV may also be suspended from overhead, using suitable mounting methods.

The Liebert XDCF is a self-contained module designed to cool Egenera's BladeFrame EX cabinets and equipment without exhausting heat into the room. Two modules may be mounted on the rear of a BladeFrame cabinet.

The Liebert XDH is installed among equipment cabinets and is particularly suited to new installations.

3.4 Airflow Requirements for Liebert XD Solutions

Computer manufacturers typically specify a temperature change from intake to exhaust (delta T) of 18-27°F (10-15°C) for the air passing through a rack enclosure. The heat generated by electronic equipment combined with the tight quarters of equipment cabinets mean that high volumes of air must move through an enclosure to meet this cooling specification.

A Liebert XD system can supply the cooled air to satisfy this cooling demand, but airflow through the enclosure must be adequate to extract the heat from the cabinet. Liebert's XDA units can boost the airflow to levels necessary to protect critical equipment. The Liebert XDA is particularly suited to the hot aisle/cold aisle arrangement.

3.5 Configuring a Liebert XD System

3.5.1 Number of Modules Supported by a Liebert XDP or Liebert XDC

The numerals designating the model size of a Liebert XD unit may be used to configure a cooling system. For example, a Liebert XDO20 has a model size of 20 and a Liebert XDP160 will accommodate cooling modules with a cumulative model size of 160.

Similarly, the minimum number of modules connected to a Liebert XDP or Liebert XDC may be calculated using the model size number for the Liebert XDP or Liebert XDC and the modules. See **Table 2**.

Table 2 Maximum and minimum modules supported by a Liebert XDP or Liebert XDC

Cooling Module Type	Liebert XDC		Liebert XDP	
	Max	Min	Max	Min
Liebert XDCF	16	6	16	4
Liebert XDH20	8	4	8	2
Liebert XDH32	5	2	5	1
Liebert XDO16	10	4	10	2
Liebert XDO20	8	4	8	2
Liebert XDV8	20	8	20	4
Liebert XDV10	16	7	16	4

Different types of Liebert XD cooling modules may be connected to the same Liebert XDP or Liebert XDC as long as the sum of their cooling capacity does not exceed the supporting Liebert XDP's or Liebert XDC's model size number.



NOTE

Connecting only Liebert XDCF modules to a Liebert XD unit is not recommended because the Liebert XDCF heat loading is dependent on server airflow and server load. Consult factory to determine if sufficient heat load is available from the server for the Liebert XD system to operate effectively.

3.6 Liebert XDO Placement

3.6.1 Determining Spacing of Liebert XDOs in an Aisle

Liebert XDO units should be placed in rows directly above the cold aisles of a room for optimum cooling. Each Liebert XDO serves an area equal in width to the cold aisle spacing, typically 12 to 16 feet (3.7 to 4.9m). The length of the area served includes any space between Liebert XDO modules in a row. Depending on the cooling capacity to be achieved, spacing between Liebert XDO modules in a row may vary from zero to as much as 6 feet (1.8m). When the spacing increases to more than 6 feet (1.8m), overall performance of the system may be negatively affected and gaps in cooling may occur.

Emerson recommends installing one Liebert XDO at the end of each aisle being cooled and to space the remainder between these end units in pairs as shown in **Figure 15**. This layout will block the incursion of hot air around the side of the end cabinets.

Figure 14 Liebert XDO placement over cold aisle

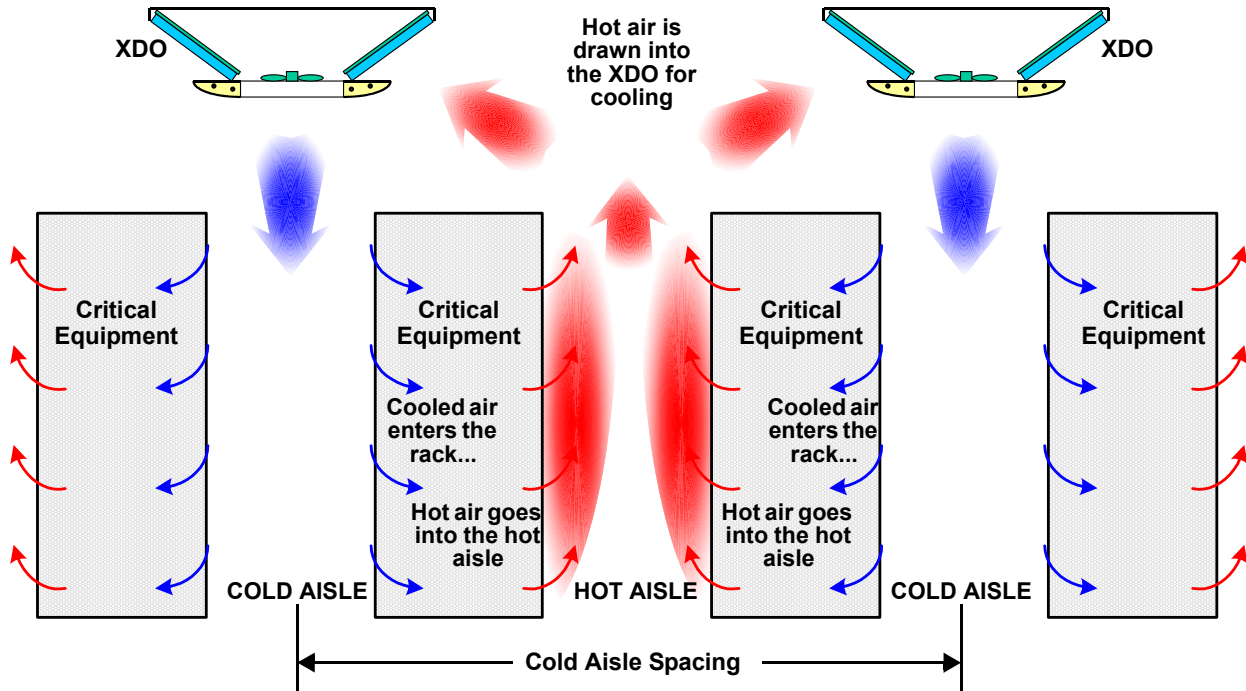

Table 3 can be used to determine the correct number and spacing of Liebert XDOs.

Table 3 Calculating quantity and spacing of Liebert XDO modules (example below is Liebert XDO20)

Input Information	Step	Result
Total heat load in the room, kW	A	
Reserve capacity needed (10% to 25% of A is recommended)	B	
	C	Required cooling capacity, kW = A + B
Existing/planned Liebert Deluxe/DS unit sensible capacity, kW	D	
	E	Required Liebert XD system cooling capacity, kW = C - D
	F	Number of Liebert XDO20s required = $E \div 20$, rounded up (60Hz) = $E \div 16$, rounded up (50Hz)
	G	Number of Liebert XDP/Liebert XDC modules required = $F \div 8$, rounded up (60Hz and 50Hz)
Room area, square feet	H	
	I	Area served by each Liebert XDO20 = $H \div F$
Spacing of cold aisles, center-to-center, typically 12-16 ft (3.7 to 4.9m)	J	
	K	Spacing between each Liebert XDO = $(I \div J) - 2$
	L	Required Liebert XD system cooling density = $E \times 1000 \div H$ OK if under 640; otherwise, additional cooling is required from Liebert Deluxe or Liebert DS units.

3.6.2 Determining Vertical Placement of Liebert XDOs Above the Cold Aisle

In the maximum density configuration, Emerson recommends placing the Liebert XDOs between 18 and 24 inches (457-609mm) above the equipment cabinets. In some cases where the required density is less, the front-to-rear spacing of Liebert XDOs in a row will be increased. To ensure coverage of the wider spaces between the Liebert XDO units, the vertical distance between the cabinets and the Liebert XDOs should be increased. However, the recommended maximum height of the Liebert XDO above the cabinets is 30 inches (762mm). See **Figures 15**.

Figure 15 Liebert XDO spacing—horizontal and vertical

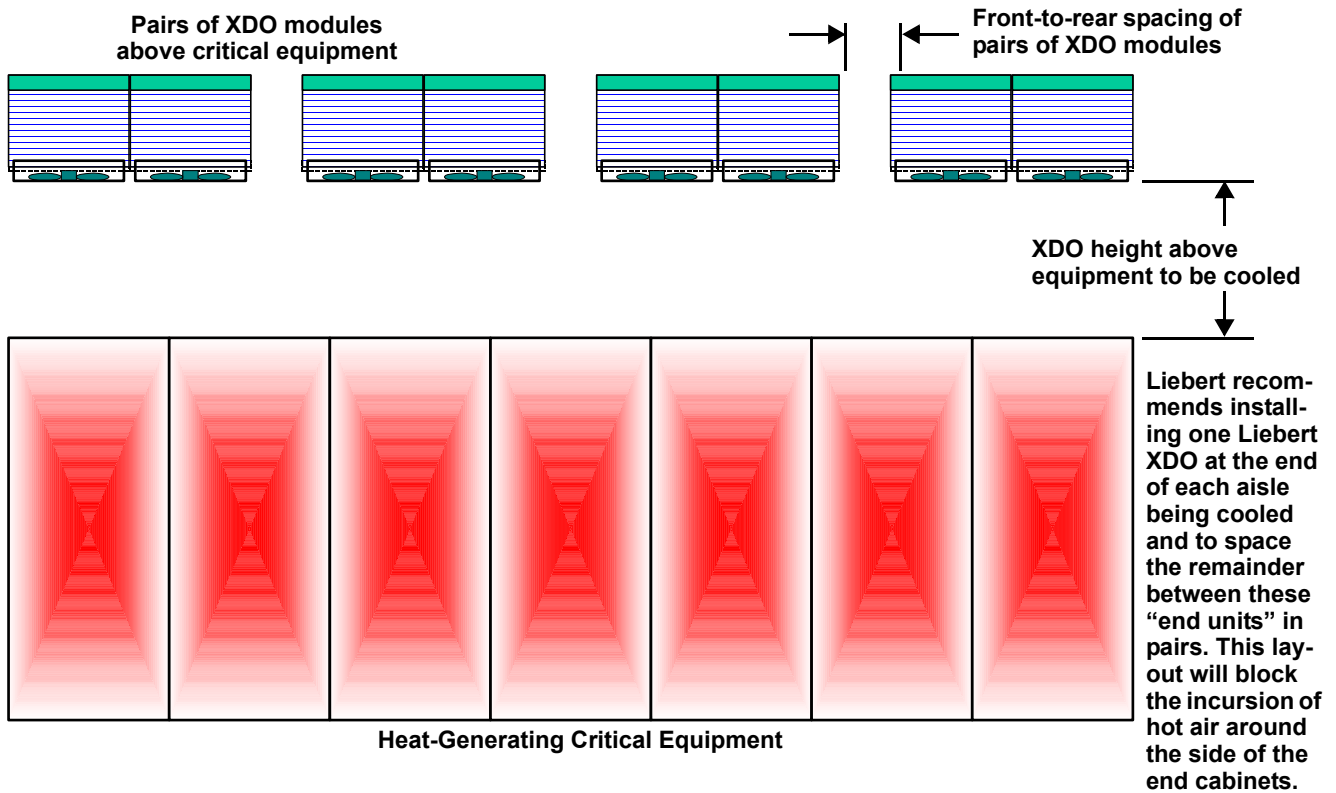

3.7 Liebert XDV Unit Placement

Liebert XDV units should be placed on top of the cabinets that generate the greatest amount of heat. If heat loads are dispersed evenly throughout the room, the Liebert XDV modules may be spread out accordingly.

The Liebert XDV must be placed toward the front of the equipment cabinet, so that its front bottom edge is flush with the front top edge of the cabinet. Placing the unit farther back on the top of the unit will restrict airflow into the cold aisle. Placing the unit farther to the front will decrease the amount of hot air drawn into the unit.

Figure 16 Positioning Liebert XDV on top of cabinet

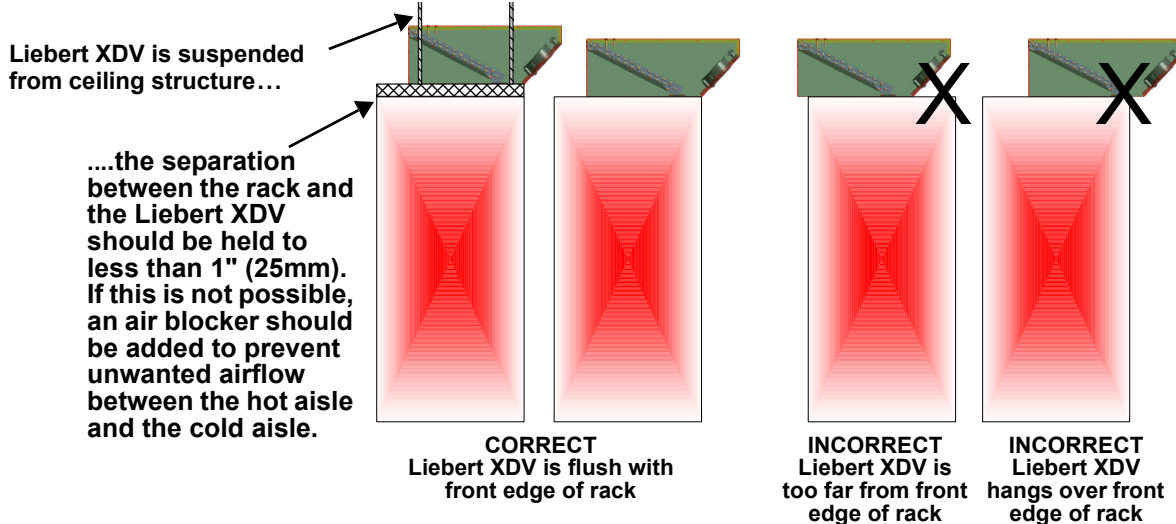

Both of the Liebert XDV's power cords should be connected to power sources. If only one power source is available, then only the power cord labeled "SECONDARY" should be connected to the power source.

Piping for the Liebert XDV is routed upward to the main return and supply pipes to and from the Liebert XDP/Liebert XDC.

Table 4, below, may be used to determine the correct number of Liebert XDV modules.

Table 4 Determine required number of Liebert XDV modules (example below is Liebert XDV10)

Input Information	Step	Results
Total heat load in the room, kW	A	
Reserve capacity needed (10% to 25% of A is recommended)	B	
	C	Required cooling capacity, kW = A + B
Existing/planned Liebert Deluxe/DS sensible capacity, kW	D	
	E	Required Liebert XD system cooling capacity, kW = C – D
	F	Number of Liebert XDV10 modules required = E ÷ 10, rounded up (60Hz) = E ÷ 8, rounded up (50Hz)
	G	Number of Liebert XDP/Liebert XDC modules required = F ÷ 16, rounded up (60Hz and 50Hz)
Room area, square feet	H	
	I	Area served by each Liebert XDV10 = H ÷ F
	L	Required Liebert XD system cooling density = E x 1000 ÷ H OK if under 580 for 12-foot cold aisle spacing OK if under 435 for 16-foot cold aisle spacing Otherwise, additional Liebert Deluxe or Liebert DS unit capacity is needed.

3.8 Liebert XDCF Placement

The Liebert XDCF is a self-contained module designed to cool Egenera's BladeFrame EX cabinets and equipment. Liebert XDCF modules attach to the rear of the Egenera BladeFrame EX cabinet, beside the power modules (see **Figure 17**). No cutting or drilling is required to attach the modules; all mounting holes, slots and pins required are fabricated at the factory. The Liebert XDCF does not require electrical connections.

The number of Liebert XDCF modules required is determined by the heat load of the cabinet—cabinets cannot share cooling from a Liebert XDCF module.

The Egenera BladeFrame EX cabinet has provisions for mounting two Liebert XDCF modules, should the heat load require two modules. If only one Liebert XDCF will be needed, Liebert recommends using the lower Liebert XDCF module.

The complete system consists of Liebert XDCF modules, piping, Liebert XDP or Liebert XDC refrigerant distribution units and those units' chillers or drycoolers.

Figure 17 Liebert XDCF unit mounting locations

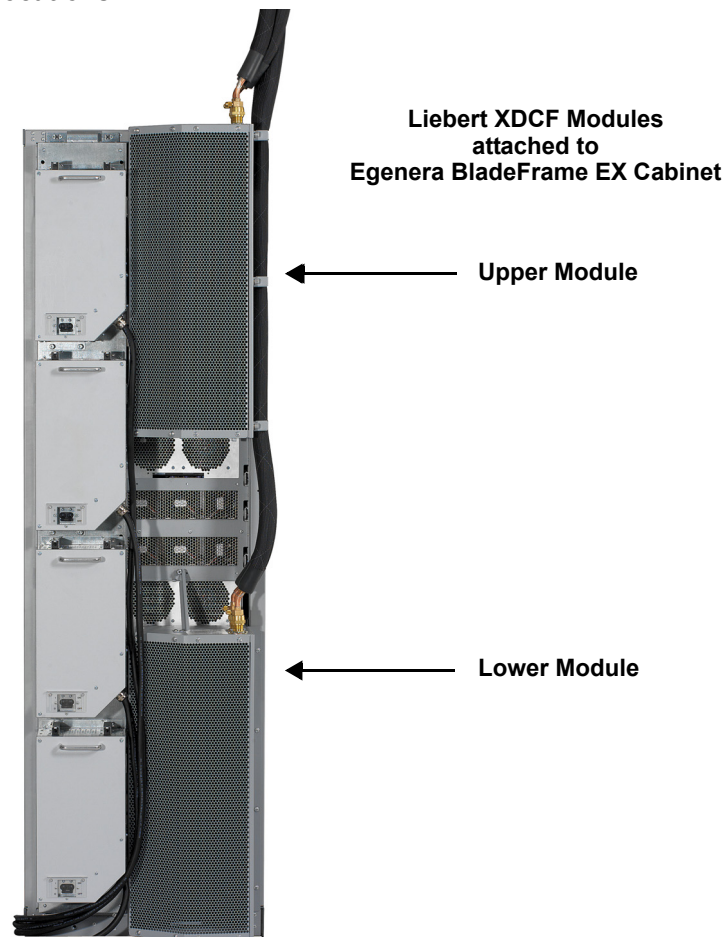

3.9 Liebert XDH Placement

The free-standing Liebert XDH cooling unit is best placed among the equipment cabinets in a hot aisle-cold aisle arrangement (see **Figure 18**). The Liebert XDH draws in air from the hot aisle, cools it and discharges the cooled air into the cold aisle where it is drawn into the equipment cabinets. Regular spacing aids in optimizing cooling.

Liebert XDH units should be placed among the cabinets that generate the greatest amount of heat. If heat loads are dispersed evenly throughout the room, the Liebert XDH modules may be spread out accordingly.

If a Liebert XDH is installed at the end of a row, Liebert recommends using uni-directional air diffusers on that Liebert XDH. The uni-directional diffusers can be used for left or right air discharge by removing them from the Liebert XDH, turning them 180 degrees, then reattaching them to the Liebert XDH.

Liebert recommends using bi-directional air diffusers on Liebert XDH modules installed between racks.

Figure 18 Liebert XDH placement

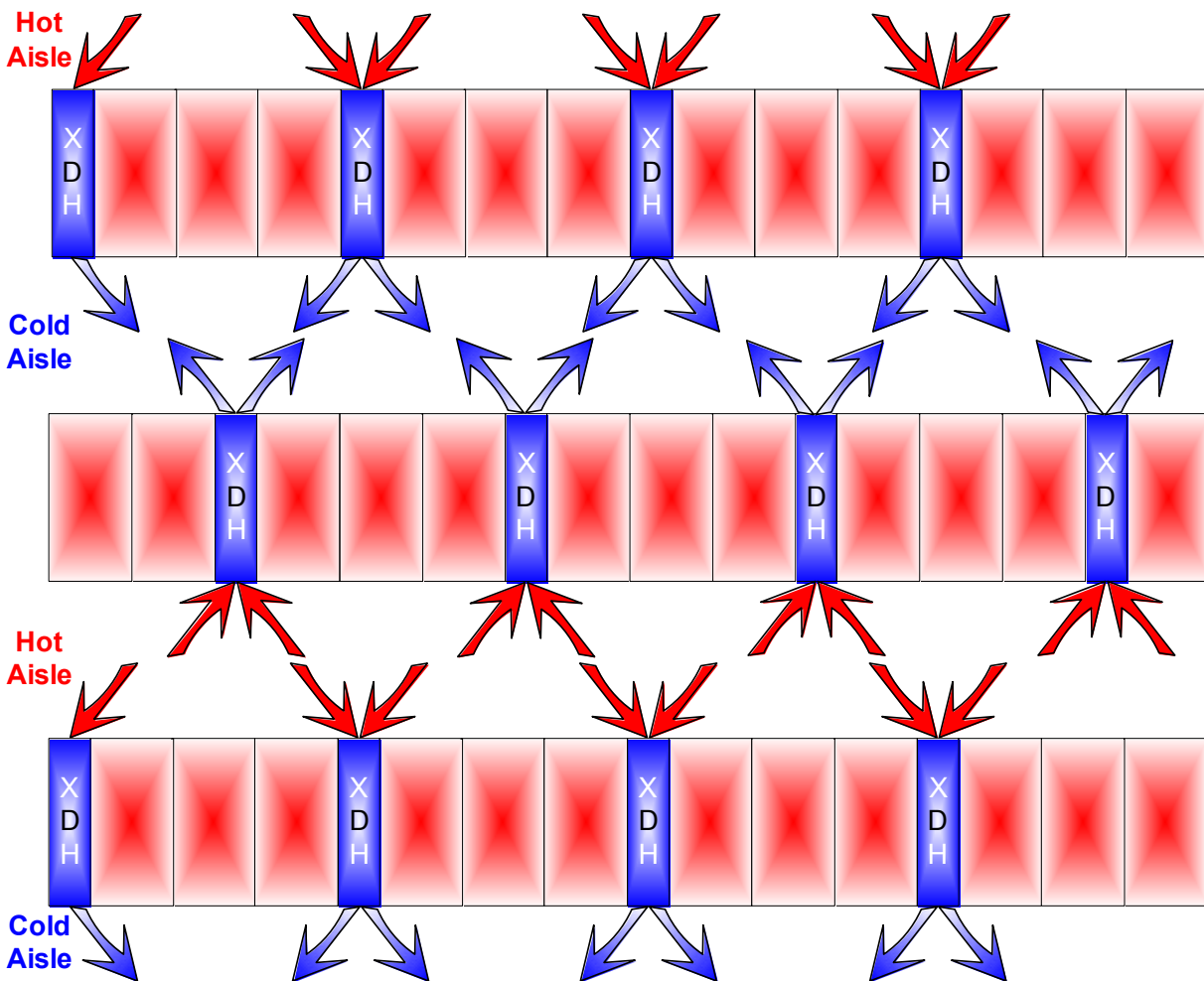

3.10 Liebert XDP/Liebert XDC Placement

The Liebert XDP/Liebert XDC may be placed in the critical space or in an adjacent equipment room. The allowable distance between the Liebert XDP/Liebert XDC and its connected cooling modules is determined by the piping design and by the amount of refrigerant required. Refer to **3.12 - Liebert XD Refrigerant** and **3.13 - Liebert XD Piping System Design**.

The maximum height of any of the main or connecting piping should be no more than 20 feet (6m) above the top of the Liebert XDP/Liebert XDC unit. Liebert XDV/Liebert XDO modules should be placed as close to the same level as possible. The differences in elevation between the highest and lowest Liebert XDV or Liebert XDO module in a system should be no more than 6 feet (2m).

3.11 Examples of Expansion and Interlaced Connection of Liebert XD Cooling Modules

Figure 19 Liebert XDV units mounted on racks emitting 3kW of heat, top view

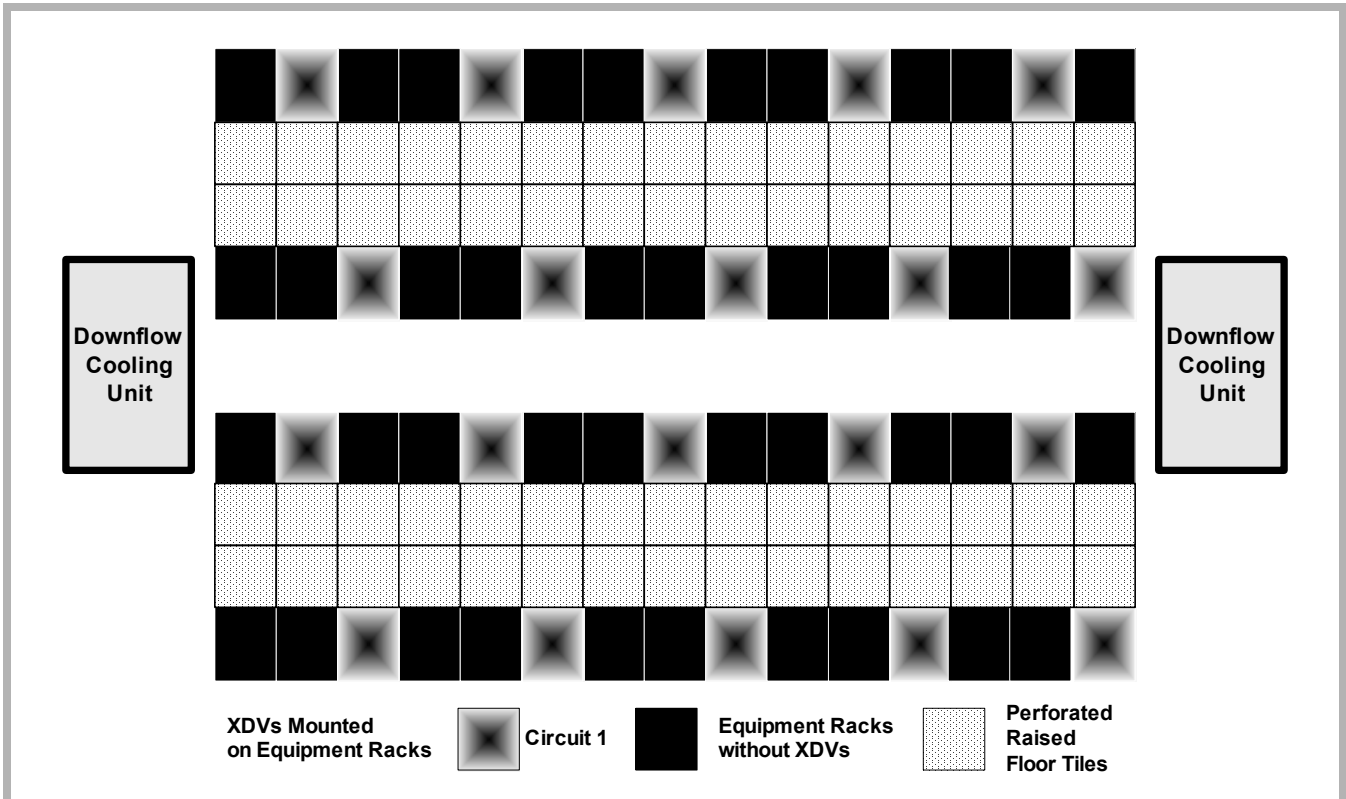

Figure 20 Liebert XDV units mounted on racks emitting 5kW of heat, top view

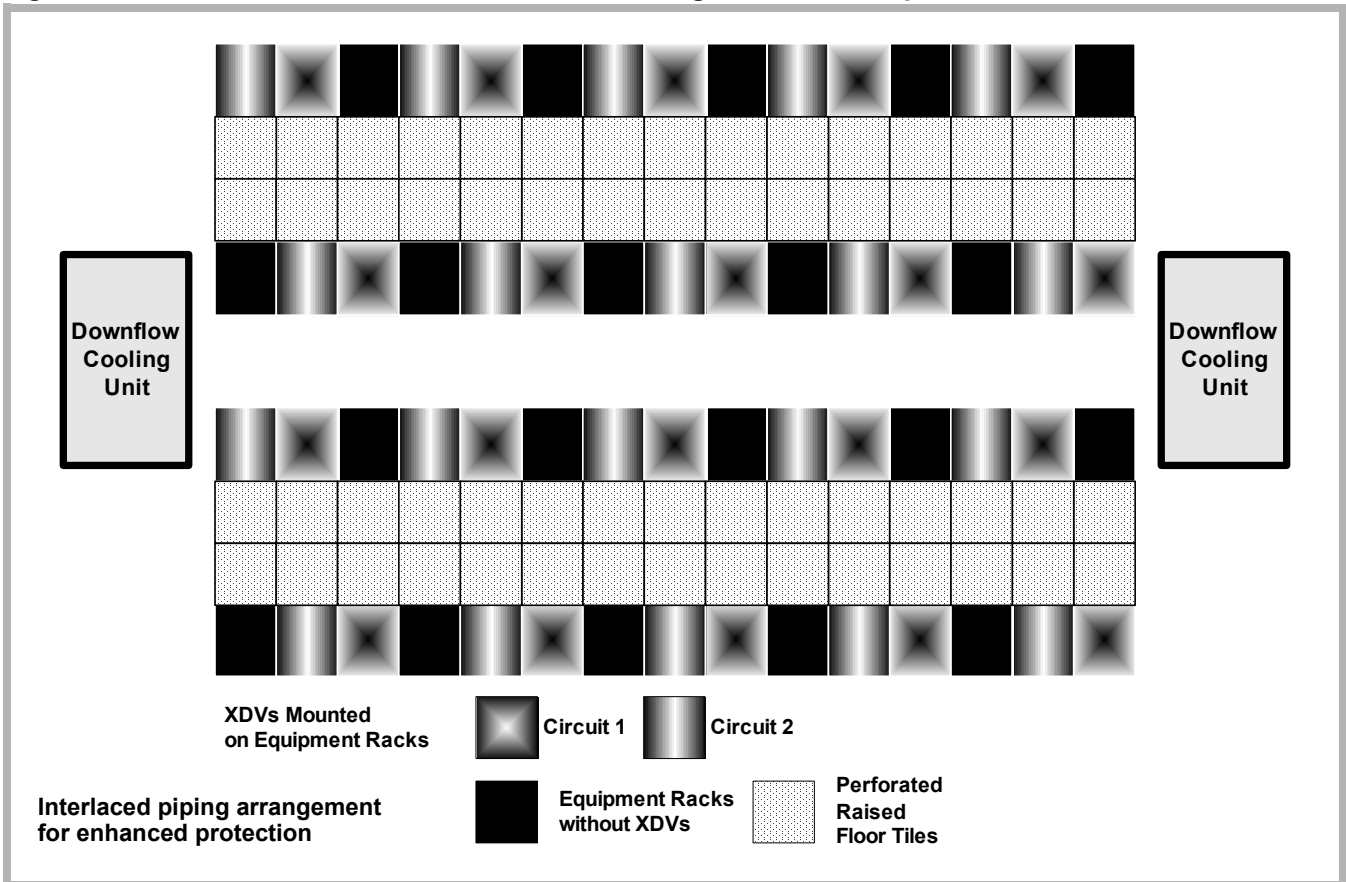

Figure 21 Liebert XDV units mounted on racks emitting 8kW of heat top view

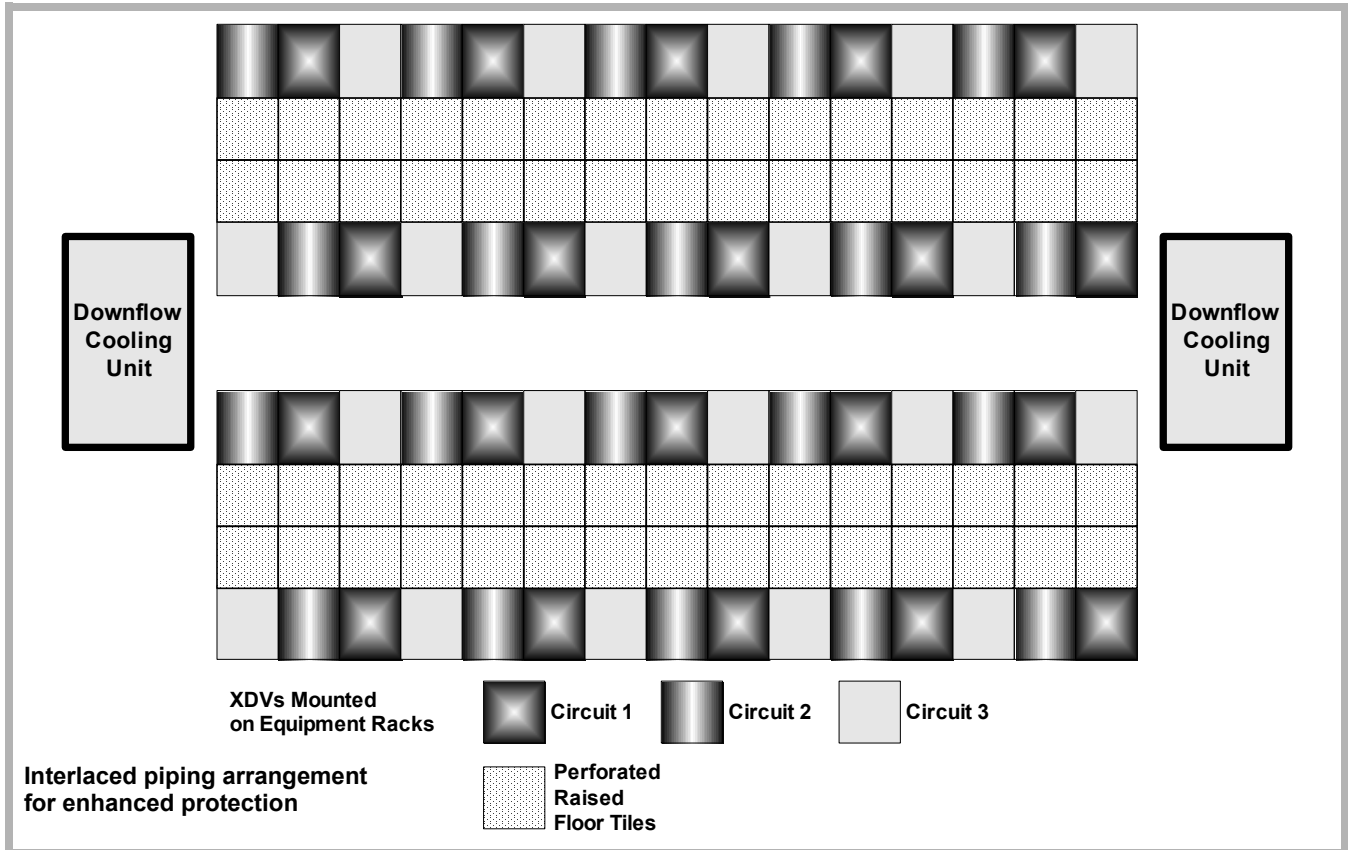
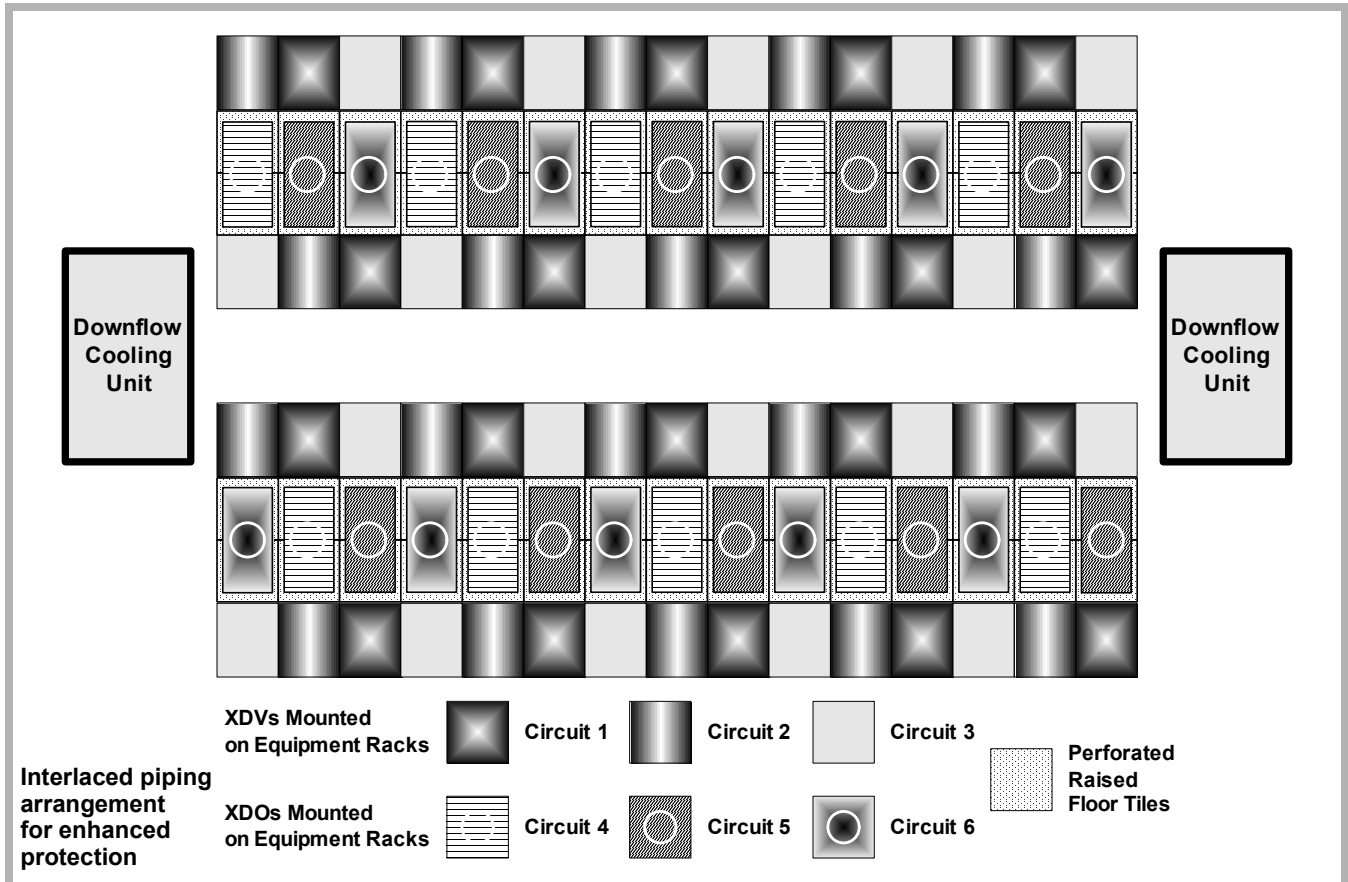

Figure 22 Liebert XDV units mounted on racks emitting 16kW of heat top view



3.12 Liebert XD Refrigerant

The refrigerant used in the Liebert XD system is HFC-134a (1,1,1,2-tetrafluoroethane), made by a number of manufacturers. The amount of refrigerant used by the Liebert XD system may be significantly higher than in typical DX cooling systems.



CAUTION

Risk of improper oil use. Can cause equipment damage.

The Liebert XD pumped R-134a refrigerant circuits do not use refrigerant oil. Do NOT put oil in the R-134a system.

All the major components of a Liebert XD system must be installed in a space with a volume of at least 1,000 ft³ (28.3m³) for each 13 pounds of refrigerant in that system from *Table 1, ASHRAE Standard 15-2001, Safety Standard for Refrigeration Systems*. If the Liebert XDP/Liebert XDC is placed in a separate area, such as a machine room, then this area must also meet the volume requirement. Inside the critical space, this includes the space under the raised floor, and the space between the top of the raised floor and the bottom of a suspended ceiling. If the suspended ceiling is all open grates, then this additional space, up to the overhead deck, would also be included.

Example

A space is 5,000 square feet, with an 18" raised floor and an 8' 6" suspended ceiling. Liebert XDOs and a Liebert XDP are to be placed in this raised-floor area.

The volume of the space is $(1.5 + 8.5) \times 5,000$ or 50,000 cubic feet.

The maximum amount of R-134a refrigerant that can be used in a single Liebert XDP/Liebert XDC/Liebert XD module system within this space is $16 * (50000/1000) = 16 * 50 = 800$ lb.

Multiple Liebert XD systems can be installed in this space, as long as the amount of R-134a refrigerant in any one system does not exceed 800 lb.



NOTE

Local codes might permit exceeding the maximum refrigerant limit stated above if refrigerant detector and an exhaust system are installed. As an alternative, oxygen sensors may be installed to meet some local codes.

3.13 Liebert XD Piping System Design

All piping must be ASTM (American Society for Testing and Materials) Type "L" copper pipe. The typical maximum operating pressure in the system is 90 psi (620kPa).

Piping for the Liebert XD system is arranged in a manner similar to piping for a chilled water system. Liebert XD cooling modules (Liebert XDCE, Liebert XDH, Liebert XDO or Liebert XDV) are connected in parallel between the main return and supply pipes going to and from the Liebert XDP/Liebert XDC.

Figure 23 represents a typical configuration. **The guidelines provided for pipe size must be strictly followed. Failure to size the main lines and connection lines adequately may result in reduced cooling capacity.** The critical aspects of pipe sizing are related to refrigerant volume and pressure drop. Each must be minimized.

Figure 23 Piping for Liebert XDP/Liebert XDC used with Liebert XD cooling units

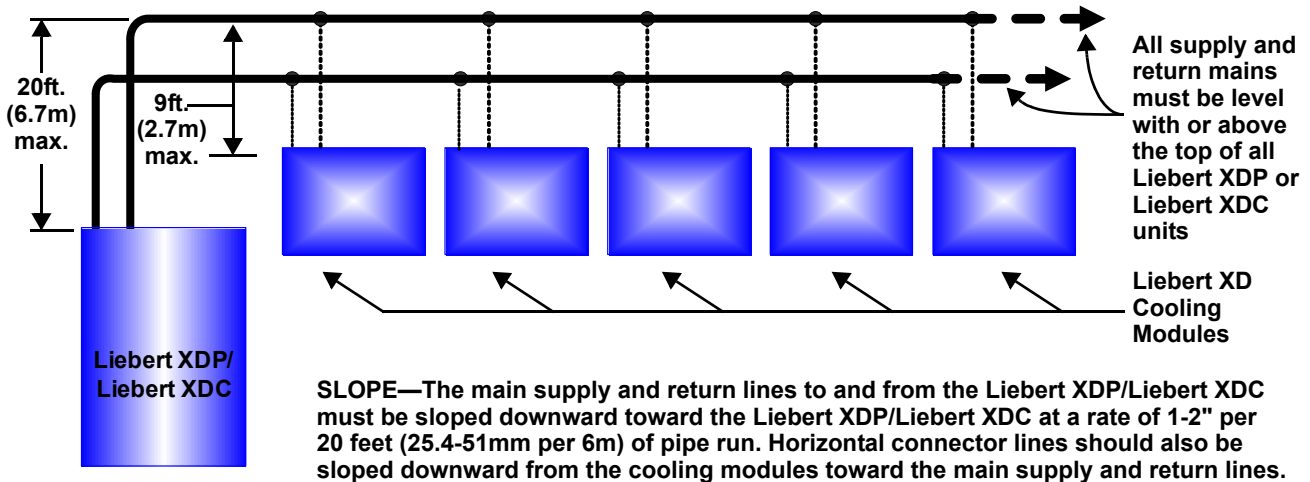

The assembly and connection means used for piping in the Liebert XD system are similar to that of conventional refrigeration systems. All piping should be installed with high temperature brazed joints. Soft solder is not recommended. The lines being brazed MUST be filled with flowing dry nitrogen during brazing to prevent excessive oxidation and scale formation inside the piping.

Insulate all piping lines to prevent condensation in applications where the dew point approaches the R-134a refrigerant temperature.

Please see **Table 5** below for recommended pipe sizes and **Figure 24** for piping segment locations.

Table 5 Supply, return pipe sizes for refrigerant loop

Pipe Function	Key to Piping in Figure 24	Size / Equivalent Pipe Length
Liebert XDP supply line, from Liebert XDP supply to farthest Liebert XD cooling module	A	1-1/8" OD for lengths up to 60 feet
		1-3/8" OD for lengths over 60 but less than 175 feet
Liebert XDP return line, from farthest Liebert XD cooling module to Liebert XDP return	B	2-1/8" OD for lengths up to 60 feet
		2-5/8" OD for lengths over 60 but less than 175 feet
From any model Liebert XDO/Liebert XDH supply to supply line of Liebert XDP	C	1/2" OD for lengths up to 10 feet
		7/8" OD for lengths over 10 but less than 25 feet
From any model Liebert XDO/Liebert XDH return to return line of Liebert XDP	D	7/8" OD for lengths up to 10 feet
		1-1/8" OD for lengths over 10 but less than 25 feet
From any model Liebert XDV/Liebert XDCF supply to supply line of Liebert XDP	C	1/2" OD for lengths up to 10 feet
		5/8" OD for lengths over 10 but less than 35 feet
From any model Liebert XDV/Liebert XDCF return to return line of Liebert XDP	D	5/8" OD for lengths up to 10 feet
		7/8" OD for lengths over 10 but less than 35 feet

For additional information about piping connections, see the unit's user manual: Liebert XDP, 16641; Liebert XDC, SL-16671; Liebert XDO, SL-16666; Liebert XDV, SL-16626; Liebert XDCF, SL-16678; and Liebert XDH20 and Liebert XDH32, SL-17210.



NOTE

To minimize the amount of refrigerant required, do NOT oversize the piping.

Figure 24 Hydraulic diagram

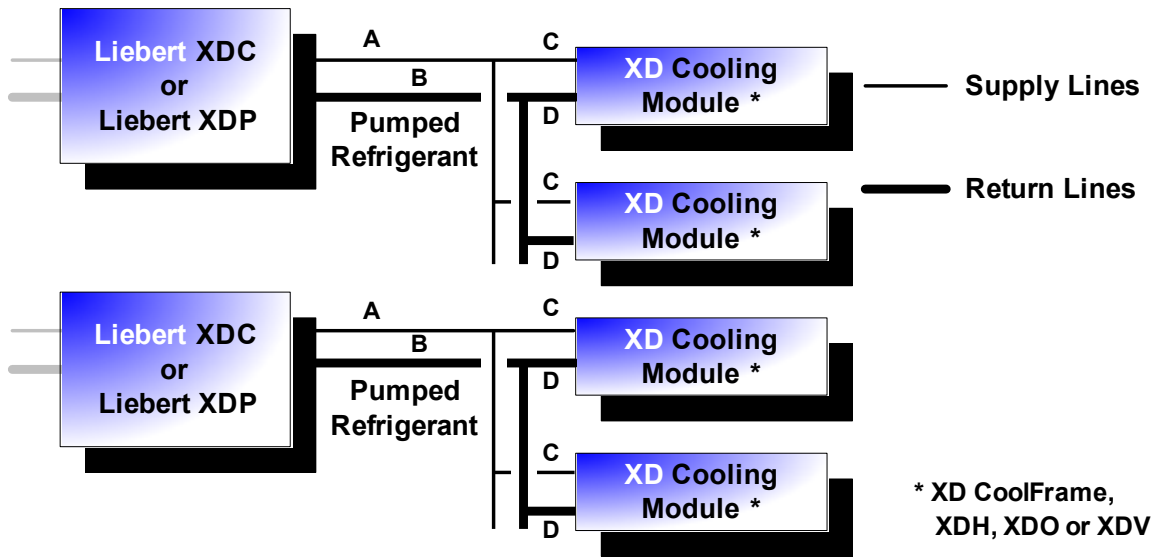

3.14 Liebert XD Piping Slope

The main supply and return lines to and from the XDP/XDC must be sloped downward toward the XDP/XDC at a rate of 1-2" per 20 feet (25-51mm per 6m) of pipe run. Horizontal connector lines should also be sloped downward from the cooling modules toward the main supply and return lines.

3.15 Bypass Flow Controllers

To ensure the XDP/XDC pumps operate within the optimum range, some installations require one or more bypass flow controller(s). These devices are added to the field piping, and simulate the flow of additional cooling modules.

Each bypass flow controller should be installed with one shutoff valve to allow the controller to be disabled when cooling modules are added to a Liebert XD system.

If bypass flow controllers are required, they should be connected between the main supply and the main return lines of the field piping. The connection points to the main supply and return lines should be in a convenient and accessible location between the Liebert XDP/Liebert XDC and the first Liebert XD module in the circuit. See **Figures 26** and **25** for piping details of the bypass flow controller.

Refer to **Table 6** to determine the number of bypass flow controllers needed, based on the total nominal cooling capacity of the cooling modules in each Liebert XD system.

Table 6 Bypass flow controllers for Liebert XDC- or Liebert XDP-based systems

Cooling Modules - Cumulative Model Size	Required Number of Bypass Flow Controllers	
	Liebert XDP	Liebert XDC
32 to 63	3	N/A
64 to 95	2	2
96 to 127	1	1
128 to 160	0	0

Figure 25 Bypass flow controller details, dimensions

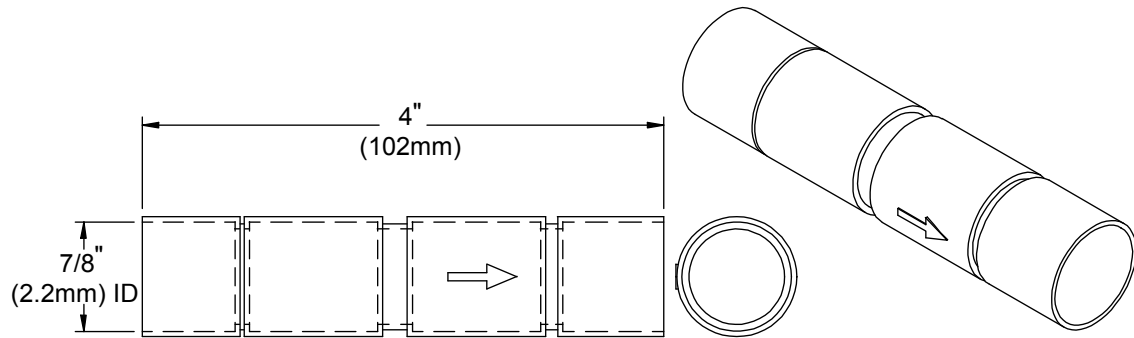

Figure 26 Bypass flow controller arrangement

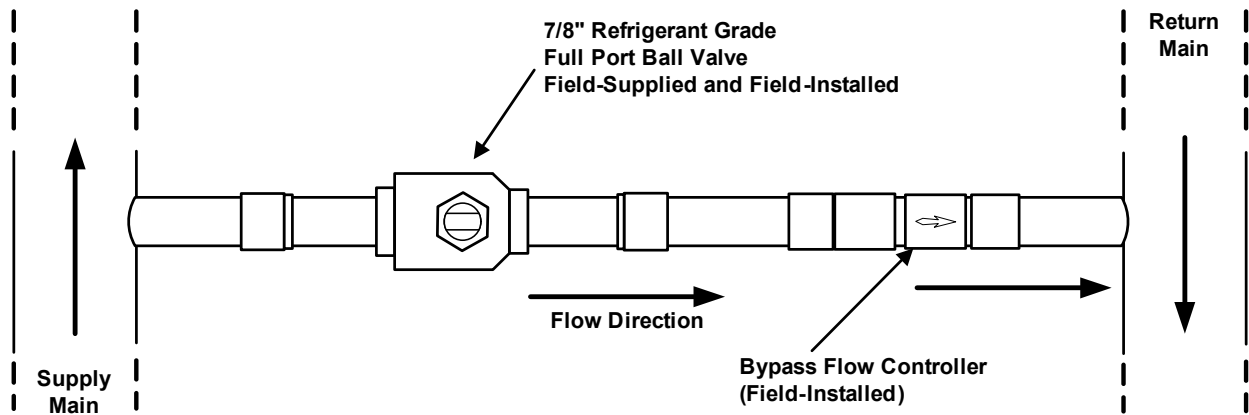
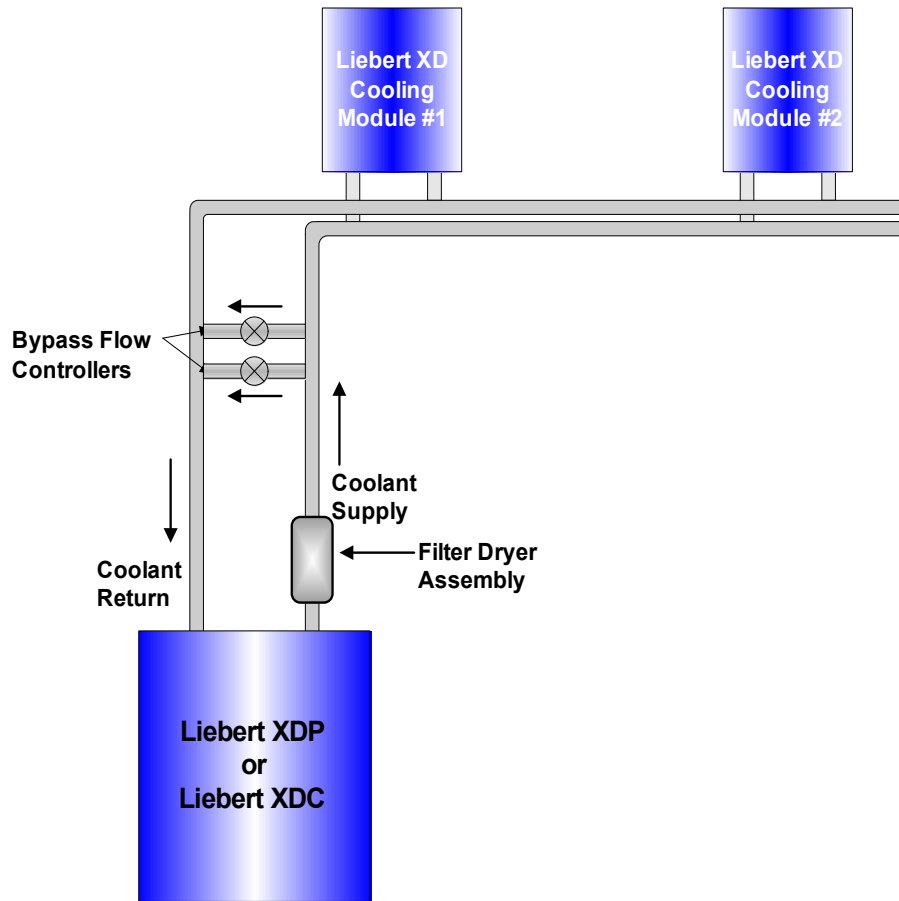

Figure 27 Bypass flow controller piping



3.16 Determining Refrigerant Volume

After the preliminary system design is completed, **Tables 7**, through **15** may be used to determine the amount of refrigerant required. Perform the calculation below for each Liebert XD system being configured.



NOTE

*All lengths in **Tables 7, 8, 9** and **10**, are actual pipe lengths, not equivalent pipe lengths.*

3.16.1 Liebert XDP/Liebert XDC Pumped R-134a Circuit Volume



NOTE

*System refrigerant volume calculations in **Tables 7, 8, 9** and **10**, are based on a fully loaded system. Additional charge may be required for lightly loaded systems.*

Table 7 System R-134a charge for a Liebert XDP/Liebert XDC with any model Liebert XDH/Liebert XDO/Liebert XDV/Liebert XDCF

Refrigerant Charge, lb (kg)	Per Liebert XD Unit (Excludes Connector Lines to and from Liebert XD Cooling Module)
157 lb. (65.7kg)	Liebert XDP/Liebert XDC
3.55 lb. (0.66kg)	Liebert XDO
2.32 lb. (1.05kg)	Liebert XDV
5.32 lb. (2.41kg)	Liebert XDH
1.41 lb. (0.64kg)	Liebert XDCF

Table 8 System refrigerant charge for the supply and return mains

Refrigerant Charge, lb/foot (kg/m)	Supply/Return Main Length and Diameter
0.45 (0.67)	Main supply actual length per 1-1/8" OD copper tubing
0.68 (1.01)	Main supply actual length per 1-3/8" OD copper tubing
0.28 (0.42)	Main return actual length per 2-1/8" OD copper tubing
0.43 (0.64)	Main return actual length per 2-5/8" OD copper tubing

Table 9 R-134a refrigerant charge for hard-piped connector lines to and from any model Liebert XDH/Liebert XDO/Liebert XDV/Liebert XDCF

Refrigerant Charge, lb/foot (kg/m)	Hard-Piped Connector Length and Diameter
0.08 (0.12)	1/2" OD Liebert XDO/Liebert XDH/Liebert XDV/Liebert XDCF supply connector actual length
0.13 (0.19)	5/8" OD copper tubing Liebert XDV/Liebert XDCF supply connector actual length
0.26 (0.39)	7/8" OD Liebert XDO/Liebert XDH supply connector actual length "
0.02 (0.03)	5/8" OD copper tubing Liebert XDV/Liebert XDCF return connector actual length
0.04 (0.06)	7/8" OD copper tubing Liebert XDV/Liebert XDCF return connector actual length
0.04 (0.06)	7/8" OD copper tubing Liebert XDH/Liebert XDO return connector actual length
0.07 (0.1)	1-1/8" OD copper tubing Liebert XDH/Liebert XDO return connector actual length

Table 10 R-134a refrigerant charge for Flex Pipe connector lines to and from any model Liebert XDO/Liebert XDH/Liebert XDV/Liebert XDCF

Refrigerant Charge, lb. (kg)	Metal Flex Pipe Connector Length
Supply Line Diameter 1/2"	
0.3 lb. (0.14)	4 ft. Flex Pipe Liebert XDH/Liebert XDO/Liebert XDV/Liebert XDCF supply
0.5 lb. (0.23)	6 ft. Flex Pipe Liebert XDH/Liebert XDO/Liebert XDV/Liebert XDCF supply
0.7 lb. (0.32)	8 ft. Flex Pipe Liebert XDH/Liebert XDO/Liebert XDV/Liebert XDCF supply
0.8 lb. (0.36)	10 ft. Flex Pipe Liebert XDH/Liebert XDO/Liebert XDV/Liebert XDCF supply
Return Line Diameter 5/8"	
0.01 lb. (0.01)	4 ft. Flex Pipe existing Liebert XDV systems
0.02 lb. (0.01)	6 ft. Flex Pipe existing Liebert XDV systems
0.03 lb. (0.01)	8 ft. Flex Pipe existing Liebert XDV systems
0.03 lb. (0.01)	10 ft. Flex Pipe existing Liebert XDV systems
Return Line Diameter 1"	
0.13 lb. (0.05)	4 ft Flex Pipe Liebert XDH/Liebert XDO/Liebert XDV/Liebert XDCF supply
0.2 lb. (0.09)	6 ft Flex Pipe Liebert XDH/Liebert XDO/Liebert XDV/Liebert XDCF supply
0.27 lb. (0.12)	8 ft Flex Pipe Liebert XDH/Liebert XDO/Liebert XDV/Liebert XDCF supply
0.33 lb. (0.15)	10 ft Flex Pipe Liebert XDH/Liebert XDO/Liebert XDV/Liebert XDCF supply

3.16.2 Calculating Refrigerant Charge—Example

Using **Tables 7, 8, 9 and 10**, calculate the refrigerant charge of the individual sections of your Liebert XD system. Add the calculated charge amounts to determine the amount of R-134a refrigerant required for one system combining a Liebert XDP with Liebert XD cooling modules (Liebert XDCE, Liebert XDH, Liebert XDO and Liebert XDV). The example below combines one Liebert XDP with 20 Liebert XDV8 cooling modules.

Table 11 Calculating refrigerant charge—example

Components	Number of Units or Piping Length, feet	Pounds Per Component	Total, lb.
Liebert XDP/Liebert XDC	1	157	157
Liebert XDV8 Cooling Modules	20	2.32	46.4
Supply Main, 1-1/8"	100	0.45	45
Return Main, 2-1/8"	100	0.28	28
Liebert XDV 1/2" supply Flex Pipes	20	0.8	16
Liebert XDV 5/8" return Flex Pipes	20	0.03	0.6
Total			293

Table 12 Worksheet to calculate refrigerant charge

Components	Number of Units or Piping Length	Pounds Per Component	Total
Total			

Verify that the refrigerant volume of the Liebert XD system with the longest piping length is within the allowable limit. If the allowable limit is exceeded, the Liebert XDP/Liebert XDC should be moved closer to the cooling modules (refer to **3.12 - Liebert XD Refrigerant** for limits and related details). Another way to shorten the total pipe length is to reroute the pipe runs.

3.17 Liebert XDC DX R-407c Circuit Volume—Air Cooled Units



CAUTION

Risk of improper lubrication. May cause equipment damage.

Liebert XDCs with refrigerant R-407c charges over 35 lb. (15.9kg) require additional oil. Refer to the Liebert XDC user manual, SL-16671, available at Liebert’s Web site, www.liebert.com

Weigh in the calculated charge based on **Tables 13, 14 and 15**.

Table 13 Indoor unit refrigerant charge—R-407c

Model 60/50 Hz	Charge/Circuit, lb. (kg)
Liebert XDC160	17.5 (8.0)

Table 14 Outdoor condenser charge—R-407c

Model	Charge / Circuit, lb (kg)
CDL830	200 (90.8)
CSL616	254 (115.2)
CSL415	200 (90.8)

Table 15 Air cooled systems - liquid line charge - R-407c refrigerant per 100 ft (30 m) of Type "L" copper tube

O.D., inches	Liquid Line, lb (kg)	Hot Gas Line, lb (kg)
3/8	3.7 (1.7)	-
1/2	6.9 (3.1)	-
5/8	11.0 (5.0)	2.2 (1.0)
3/4	15.7 (7.1)	3.1 (1.4)
7/8	23.0 (10.4)	17.5 (8.0)
1-1/8	39.3 (17.8)	7.8 (3.5)
1-3/8	59.8 (27.1)	11.8 (5.4)
1-5/8	-	16.7 (7.6)

Table 16 Indoor water/glycol cooled module – R-407c refrigerant charge

Model 60 Hz	Charge / Circuit, lb(kg)
Liebert XDC 160	30.0 (13.2) per circuit

3.18 Chilled Water Piping

The Liebert XDP is offered only with a two-way chilled water control valve. Some applications may require the use of a pressure activated bypass valve, to prevent dead-heading of the chilled water pump. This bypass valve must be specified by the engineer responsible for design of the chilled water field piping system.

Chilled water connections to the Liebert XDP are near the bottom of the unit. Refer to the Liebert XDP user manual (SL-16641) for further information. Piping is routed downward from the unit to chilled water piping under the raised floor. Connections are made using standard practices for copper chilled water piping. Victaulic® connections may be used to simplify installation in existing facilities. Refer to **Table 31** for additional information.

3.19 Electrical

Make all wiring and electrical connections in accordance with local and national codes. Refer to the applicable table in **5.0 - Specifications** regarding wire size and circuit protection requirements. Refer to electrical schematic when making connections.

3.20 Display Panel and Remote Temperature/Humidity Sensor Locations

The display panel must always be installed in the conditioned space. The display panel may be mounted on the Liebert XDC/XDP's front door if the unit is located in the area that it conditions.

The remote temperature / humidity sensor for the Liebert XDP and the Liebert XDC should be located in the higher-temperature portion of the cold aisle where the XD modules are located. Alternatively, it can be placed on the return air side of the primary air mover (e.g., Liebert Deluxe System/3™) in the room if it represents the conditions where all the XD cooling modules are located. It should not be installed where ambient air might cause false readings, for example, near unsealed doors, windows and similar areas.

4.0 LIEBERT XD COOLING MODULES—LIEBERT XDO, LIEBERT XDV, LIEBERT XDH AND LIEBERT XDCF

4.1 Liebert XDO Standard Features

- **Micro Channel Heat Exchanger**—The Liebert XDO unit includes two all-aluminum micro channel heat exchangers.
- **Fan**—Air is drawn in the sides of the unit through the heat exchangers and is discharged by the fan to the area below—Liebert XDO fan tray hinges down to allow access to replace or service all electrical components.
- **Internal Mounting**—The Liebert XDO unit is typically suspended from the overhead building structure by inserting field-supplied threaded rods into the internal mounting brackets.

4.1.1 Optional Features Liebert XDO

- **Refrigerant Pre-Charge**—Liebert XDO units with the pre-charged refrigerant option will have one-shot style fittings or removable couplings that contain pressurized refrigerant inside the Liebert XDO. The fittings ease connection to Liebert XD Piping and filling with refrigerant.
- **Field-Installed Flexible Piping** (for use with prefabricated piping assemblies)—Field-installed flexible piping kits are available in lengths of 4, 6, 8 and 10 feet (1.2, 1.8, 2.4 and 3 meters). Connection style to the unit end may be straight or 90 degrees. Connection to the prefabricated piping assembly is with a threaded coupler. For information on acquiring the correct kit for your installation, refer to DPN000780, available by calling 1-800-LIEBERT and from your local Emerson Network Power representative.
- **External Mounting Brackets**—The Liebert XDO unit can be suspended by external mounting brackets that are attached to the front and rear panels of the unit. The external mounting brackets are optional ship-loose items.
- **Condensate Detection**—The Liebert XDO unit is available with optional factory-installed condensate detection. The condensate detection has connection points (dry contacts) inside the unit.
- **Lighting Fixture**—Field-installable lighting fixtures are available in two voltages, 120V and 277V. Light Fixture maybe attached to the bottom of the light panel to the left and right of the fan. Each fixture consists of housing, reflector, ballast and diffuser. Fixtures are compatible with standard 48" fluorescent tubes. Lamps are not included.

Figure 28 Dimensional data—Liebert XDO hard-piped units

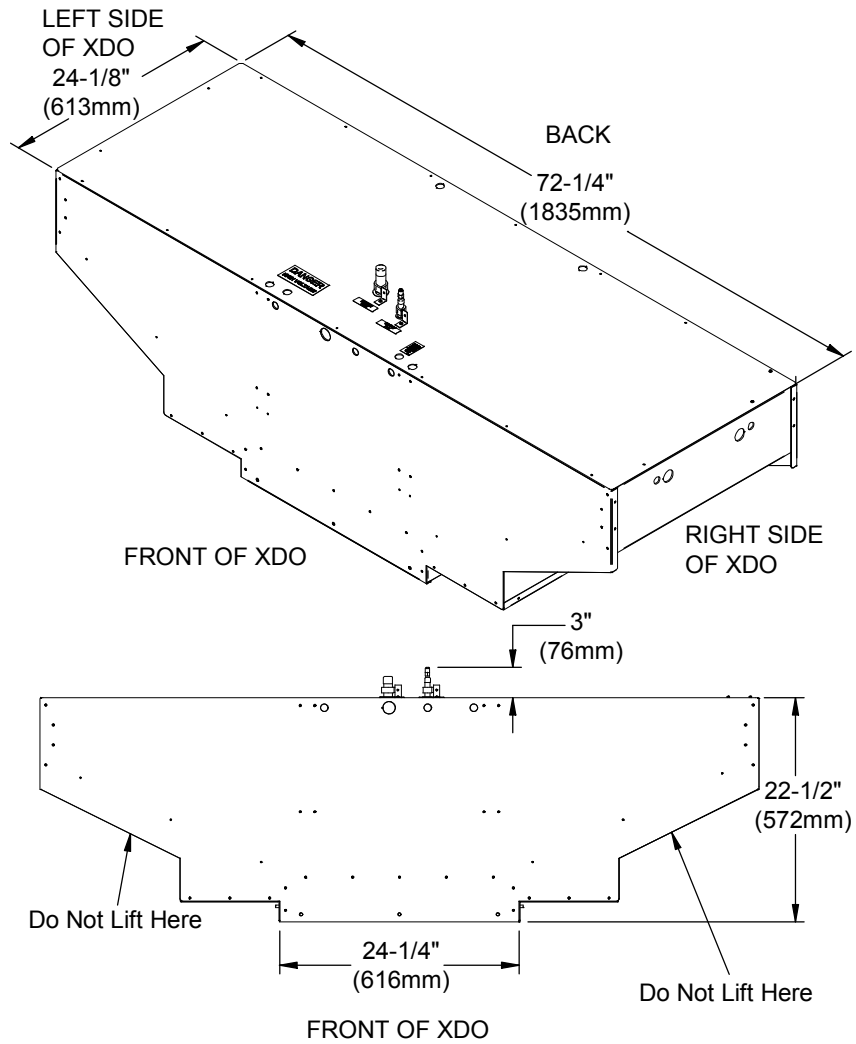

Figure 29 Dimensional data—Liebert XDO with pre-charged option

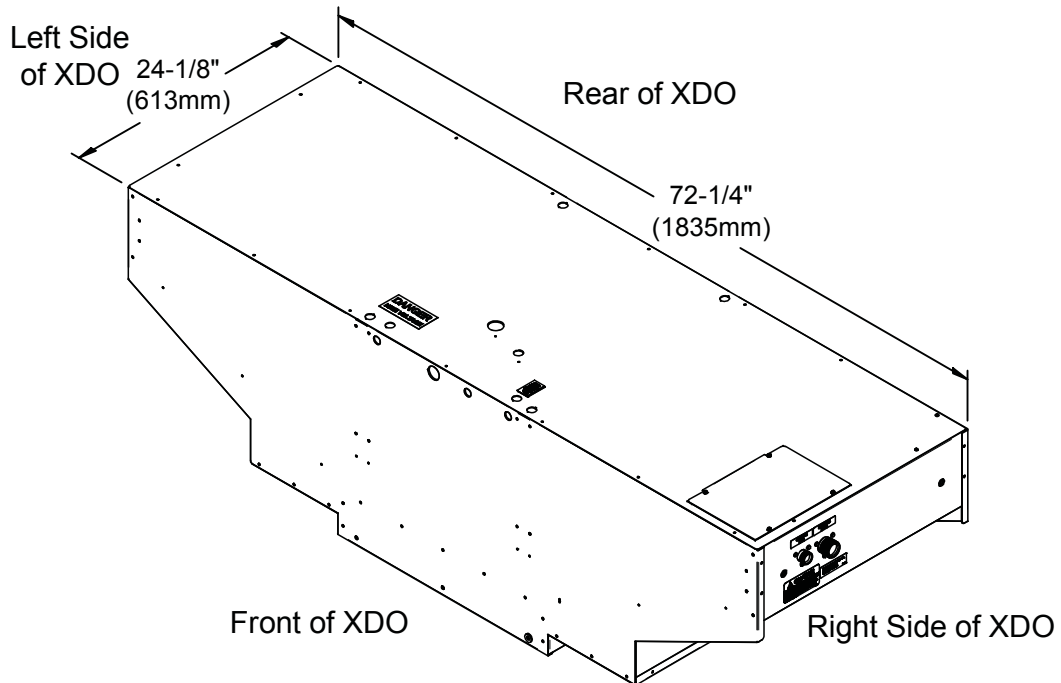
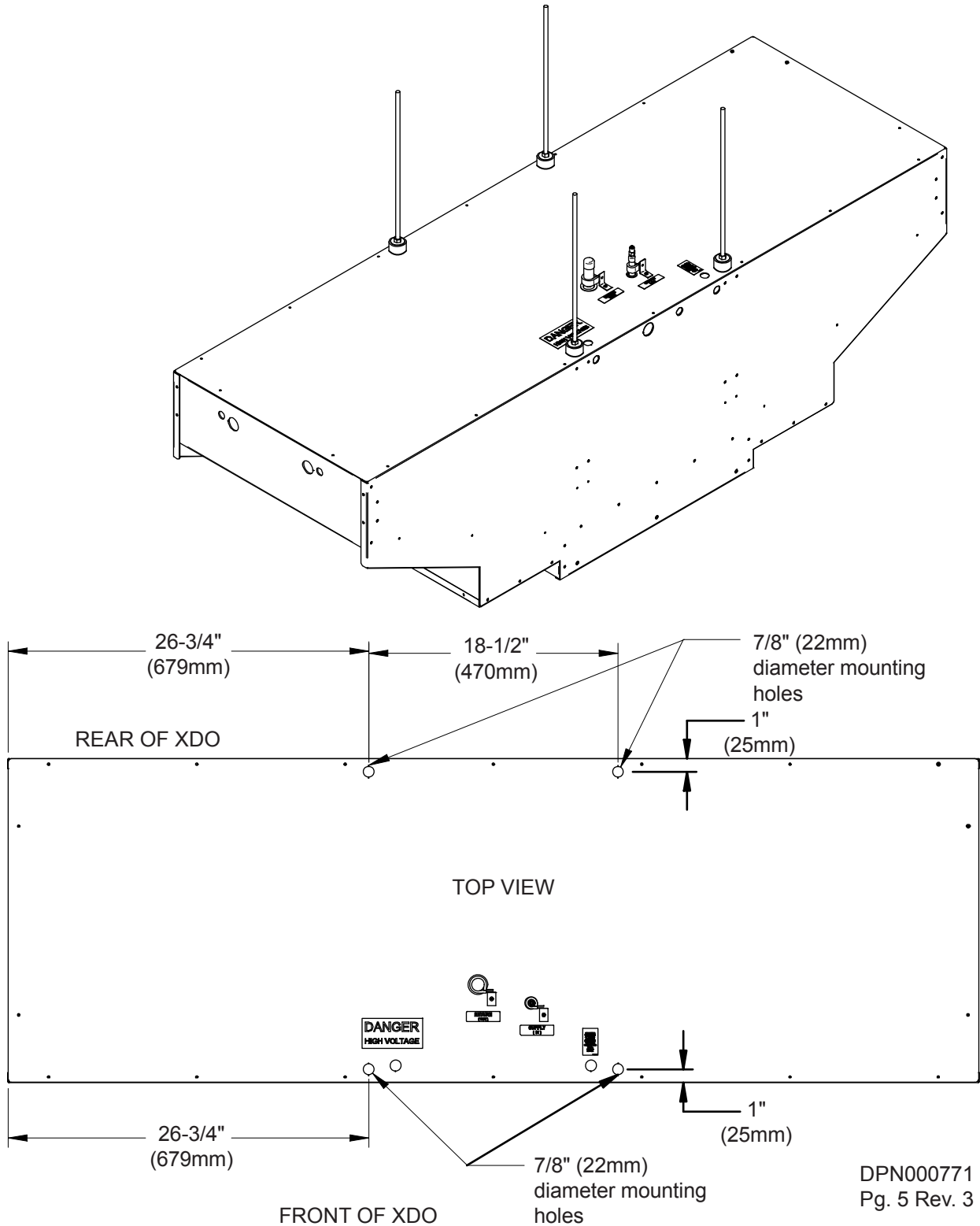
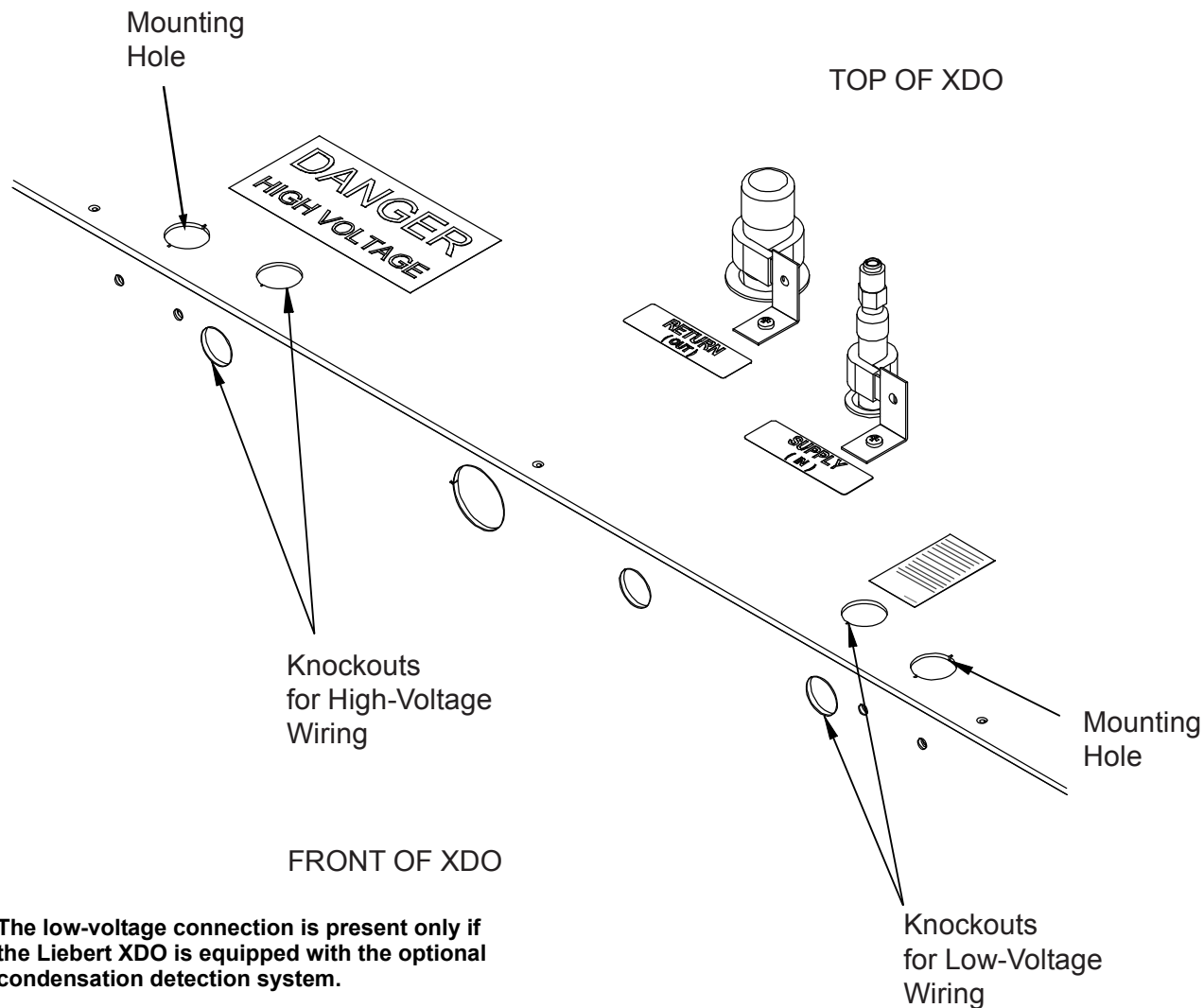

Figure 30 Liebert XDO internal mounting location



DPN000771
Pg. 5 Rev. 3

Figure 31 Liebert XDO top and front electrical access points



The low-voltage connection is present only if the Liebert XDO is equipped with the optional condensation detection system.

4.2 Liebert XDV Standard Features

- **Micro Channel Heat Exchanger**—The Liebert XDV unit includes one all-aluminum micro channel heat exchanger.
- **Dual IEC Power Cords and Power Inlets**—The Liebert 115V, 60Hz Liebert XDV unit is supplied with two detachable, 10 ft (3m) power cords that attach to two IEC power inlets in the rear of the unit. Each power cord has a NEMA 5-15P (IEC 320-C14) plug at the opposite end. The Liebert 230V, 60/50 Hz Liebert XDV unit is supplied with two non-detachable 10 ft (3m) power cords. This feature allows the unit to be powered by two separate power sources.
- **Dual Air Inlets**—The Liebert XDV unit can be configured to allow air to enter from the rear grille or the bottom of the unit.
- **Dual Fans**—Airflow is provided by two fans on the front of the unit. **Dual switches**—Controls on the front of the unit permit the use of one fan or both fans.
- **Foundation Mounting**—There are two 1/4-20 cage nuts located on the underside of unit which allow direct attachment to any Liebert Foundation cabinet, bolts provided with Liebert XDV unit.
- **Mounting Clips for non-Liebert cabinets**—The Liebert XDV unit is supplied with mounting clips that allow attachment to a non-Liebert cabinet (Some drilling may be required).

4.2.1 Optional Features—Liebert XDV

- **Refrigerant Pre-Charge**—Liebert XDV units with the pre-charged refrigerant option will have one-shot style fittings or removable couplings that contain pressurized refrigerant inside the Liebert XDV. The fittings ease connection to Liebert XD Piping and filling with refrigerant.
- **External Mounting Brackets**—The Liebert XDV can be suspended from the overhead building structure. The external mounting brackets are ship-loose items.
- **Field-Installed Flexible Piping** (for use with prefabricated piping assemblies)—Field-installed flexible piping kits are available in lengths of 4, 6, 8 and 10 feet (1.2, 1.8, 2.4 and 3 meters). Connection style to the unit end may be straight or 90 degrees. Connection to the prefabricated piping assembly is with a threaded coupler. For information on acquiring the correct kit for your installation, refer to DPN000781_Rev1, available from Liebert by calling 1-800-LIEBERT and from your local Emerson Network Power representative.
- **Condensate Detection**—The Liebert XDV unit is available with factory-installed condensate detection. The condensate detection has connection points (dry contacts) at the external rear of the unit.

Figure 32 Liebert XDV dimensions

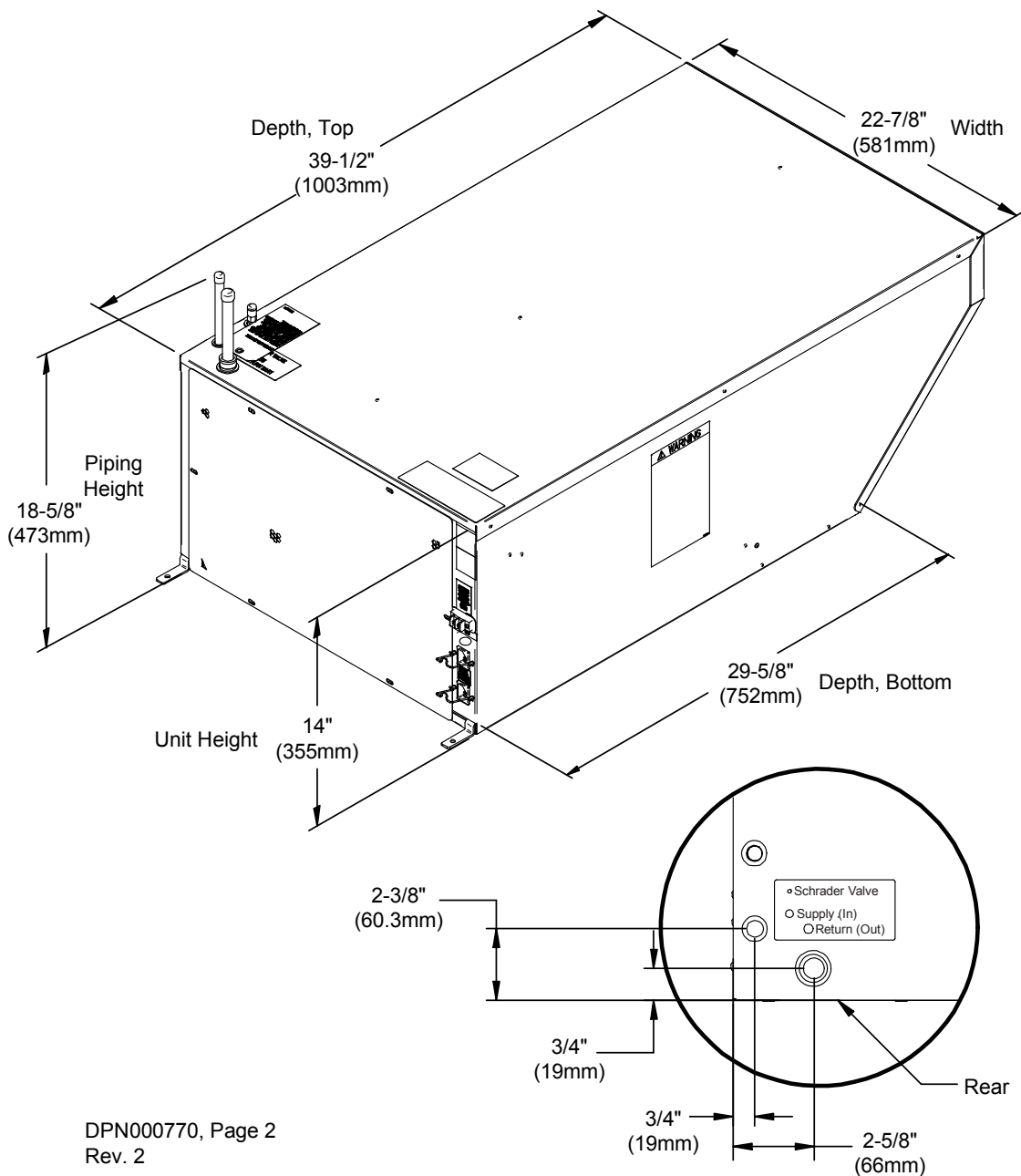

DPN000770, Page 2
Rev. 2

Figure 33 Liebert XDV dimensions with one-shot connection

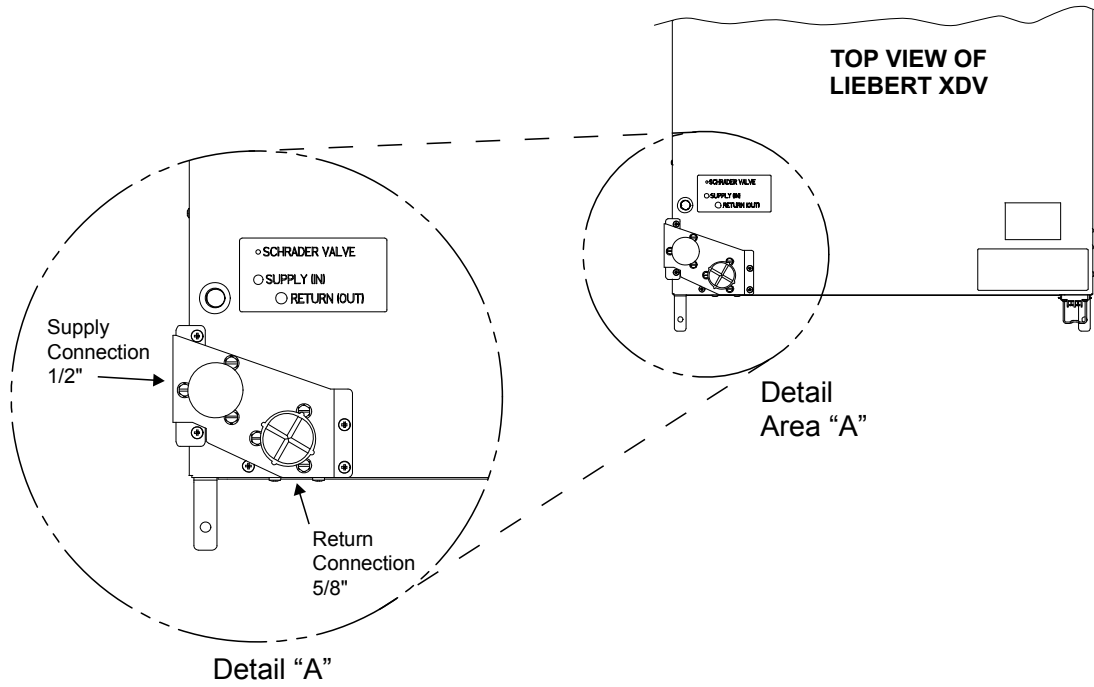

Figure 34 Liebert XDV electrical connections for CE approved units

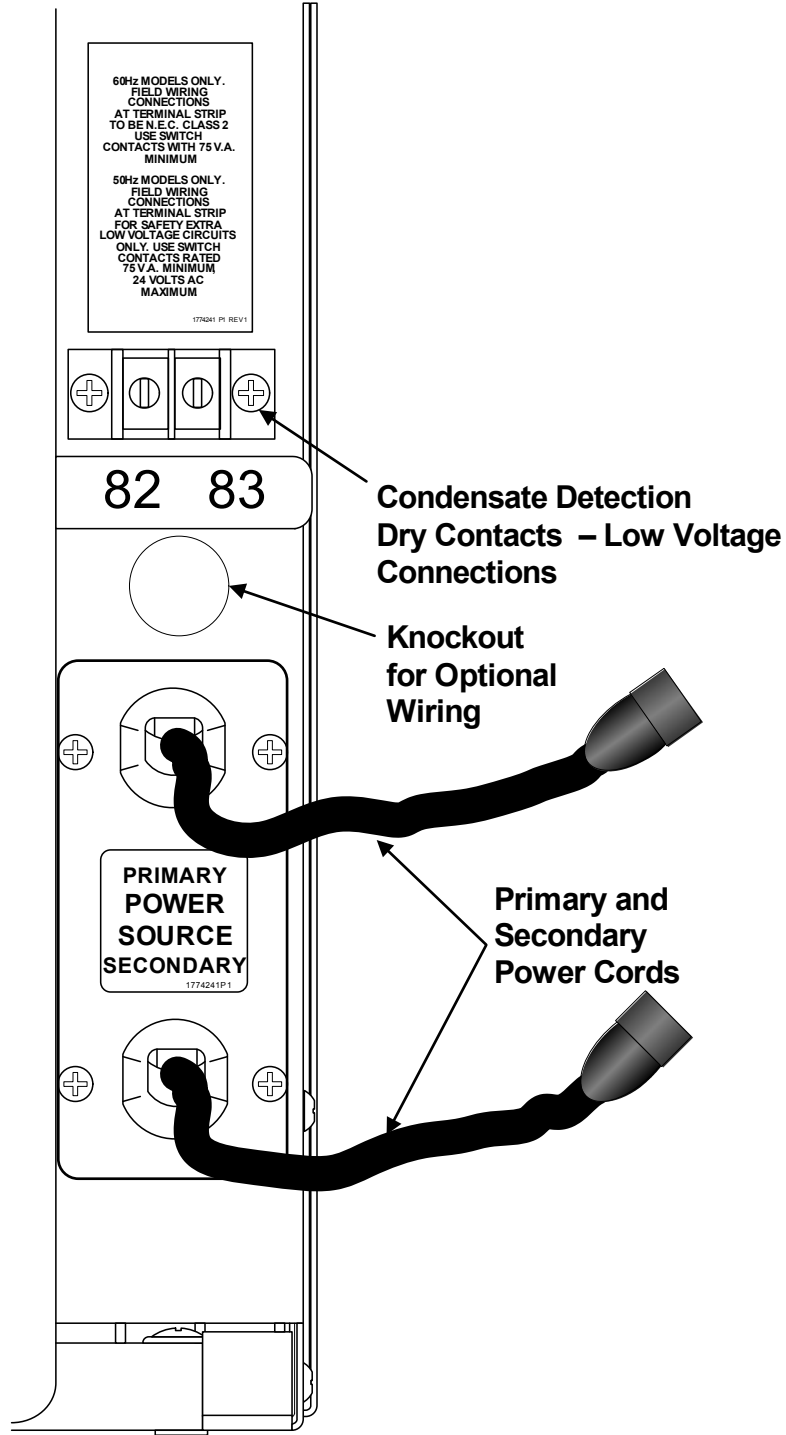

Figure 35 Liebert XDV electrical connections for CSA-approved units

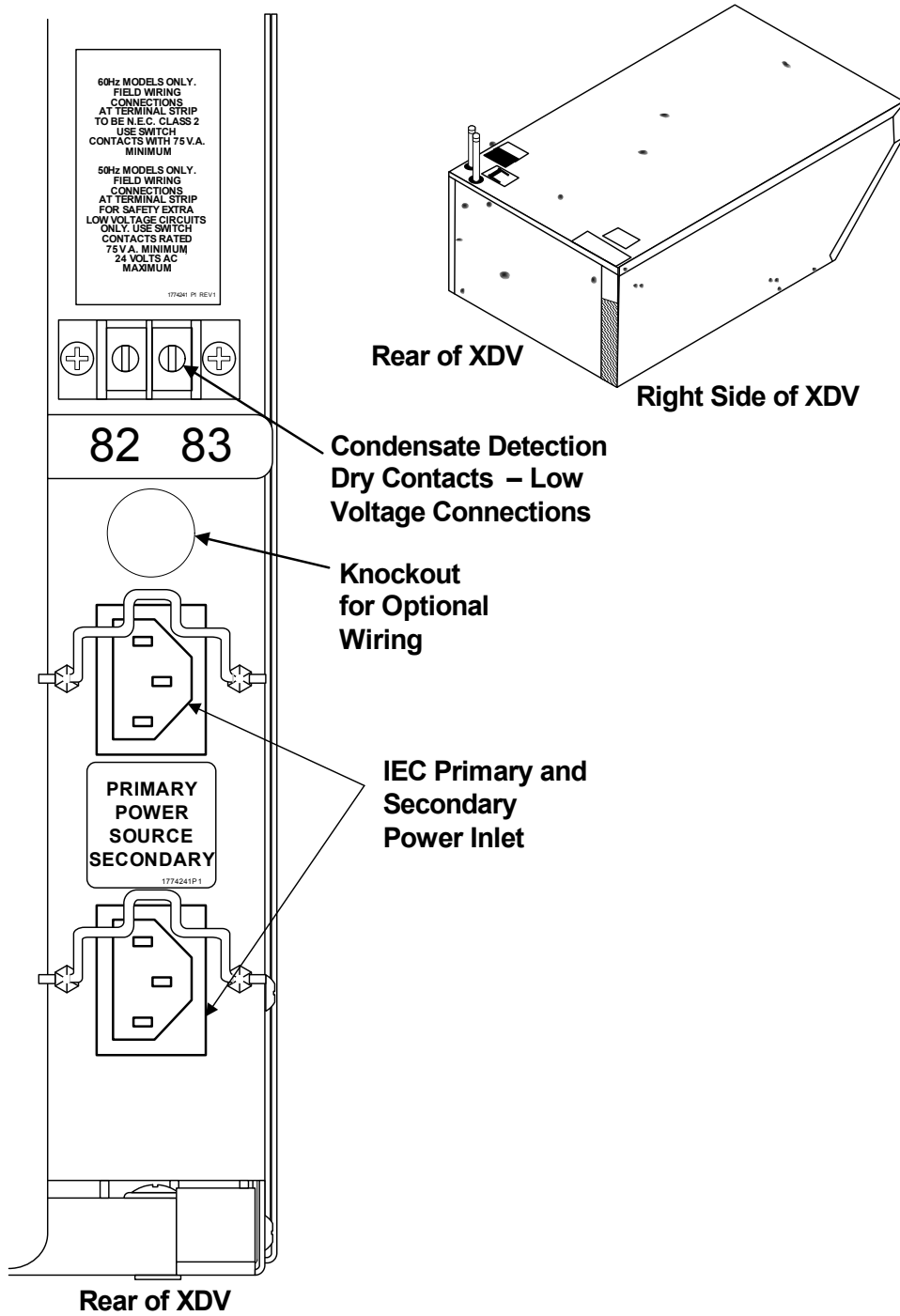

Figure 36 Suspending single Liebert XDV from Unistruts

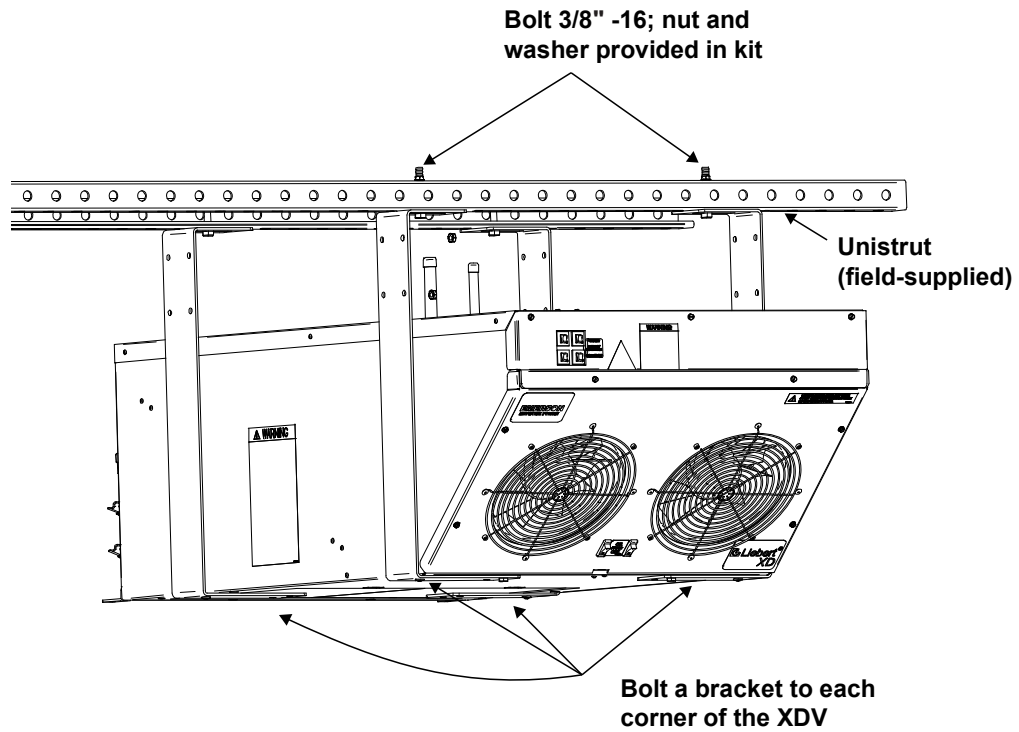

Figure 37 Suspending single Liebert XDV from the roof structure

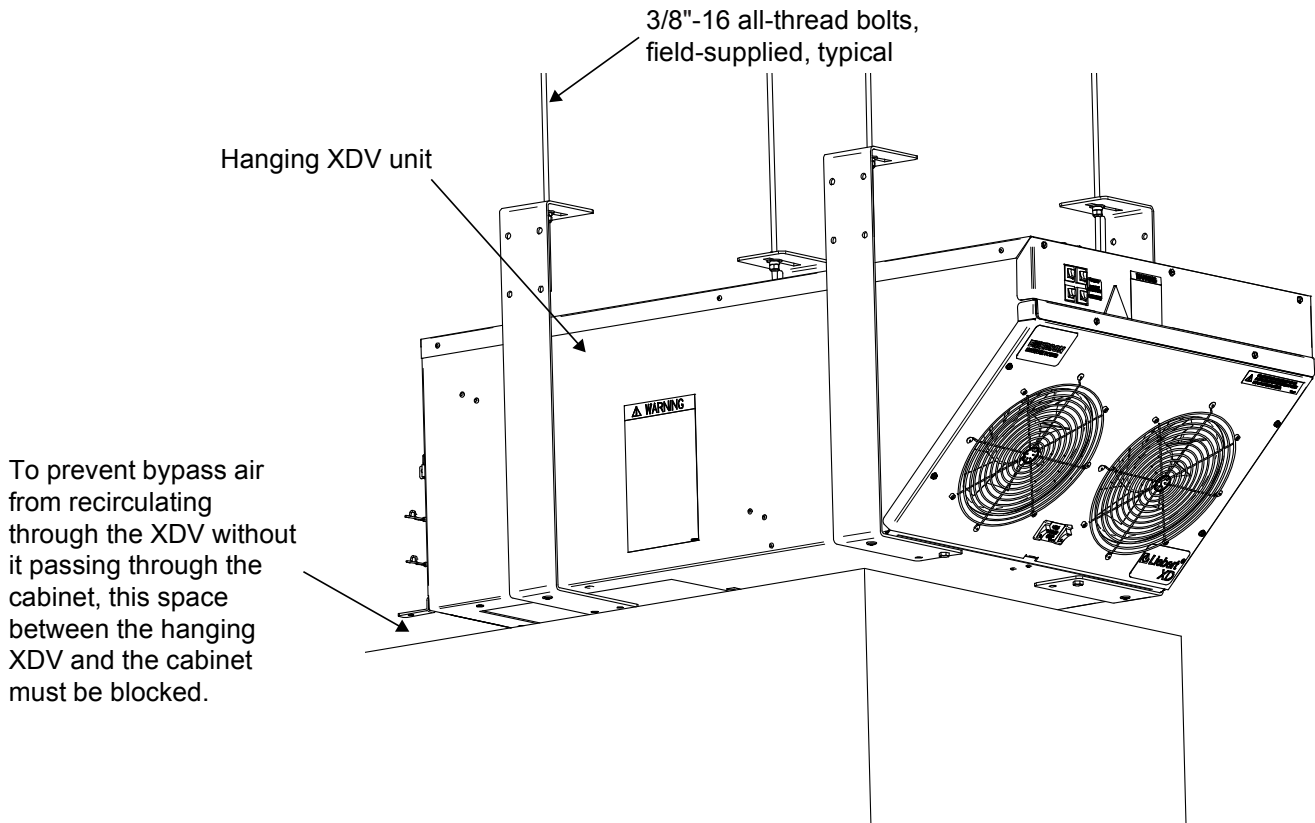
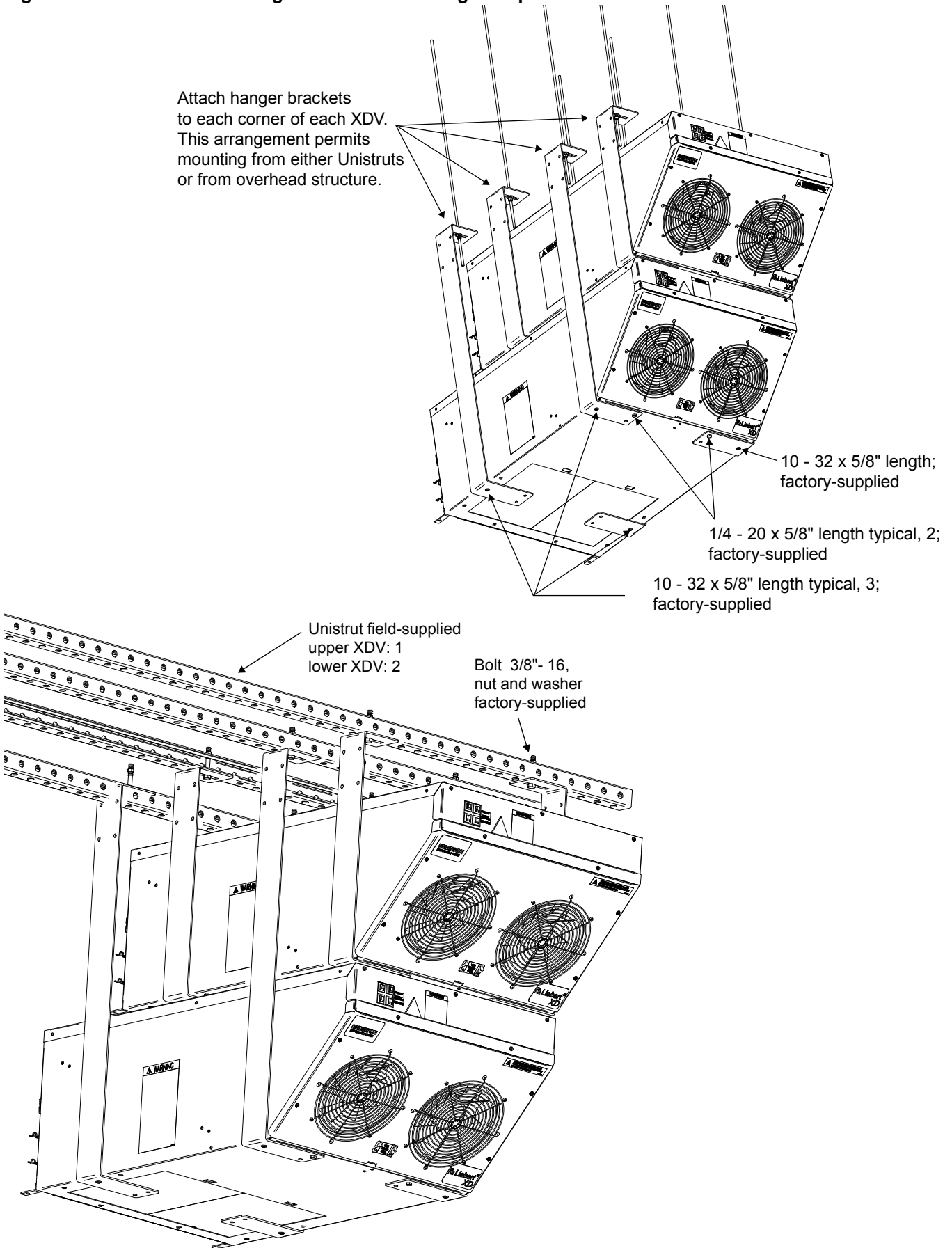

Figure 38 Alternative mounting methods—mounting multiple Liebert XDV units



4.3 Liebert XDCF Standard Features

The Liebert XDCF is a self-contained module designed to cool Egenera’s BladeFrame EX cabinets and equipment without exhausting heat into the room.

Upper and lower modules may be mounted on the rear of an Egenera BladeFrame. Liebert XDCF modules use R-134a refrigerant. When attached to a fully loaded BladeFrame EX rack, each Liebert XDCF module has a nominal cooling capacity of 10kW (2.8 tons; 34,000 BTUh). Performance is based on:

- Entering fluid temperature—55°F (12.8°C) and
- Dew point—50°F (10°C) or lower.

Liebert XDCF modules consist of a sheet-metal frame, coil and filter dryer. It has no moving parts and needs no electricity.

The Liebert XDCF system (see **Figure 39** below) consists of:

- Liebert XDCF modules—upper and lower models are available
- Flex pipe—connects Liebert XDCF units to supply and return piping
- Liebert XD Piping—delivers pumped R-134a refrigerant through flexible piping
- Liebert XDP or Liebert XDC—supplies R-134a refrigerant to Liebert XDCF modules (see Liebert XDP or Liebert XDC user manual for required chiller or drycooler)

Figure 39 Liebert XDCF hydraulic diagram

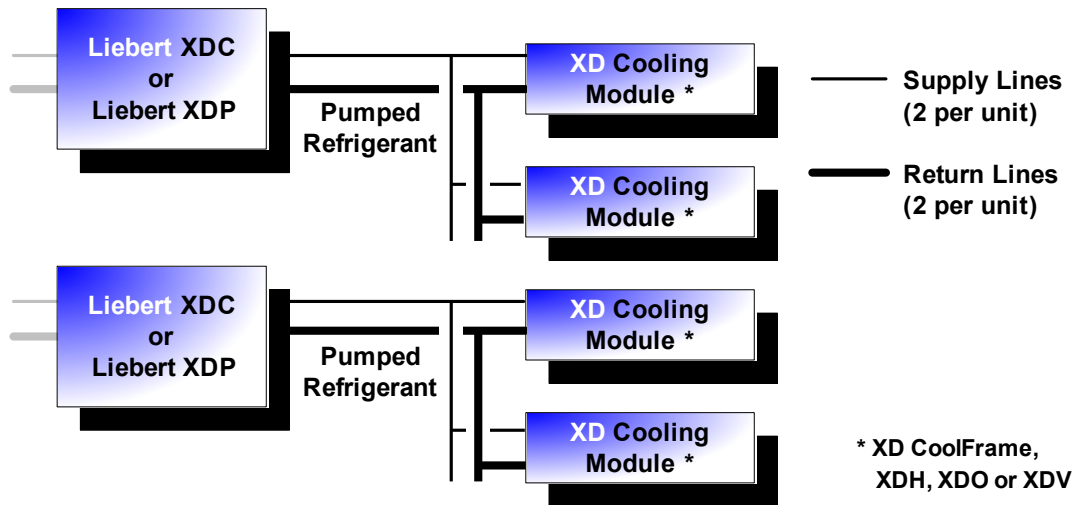

4.4 Liebert XDCF Mechanical Considerations

The Liebert XDCF is engineered to fit on the rear of the Egenera BladeFrame enclosure. **Figure 40** illustrates the unit's dimensions and the location of pipes. **Figure 41** shows the attachment positions of each module.

Figure 40 Overall dimensions

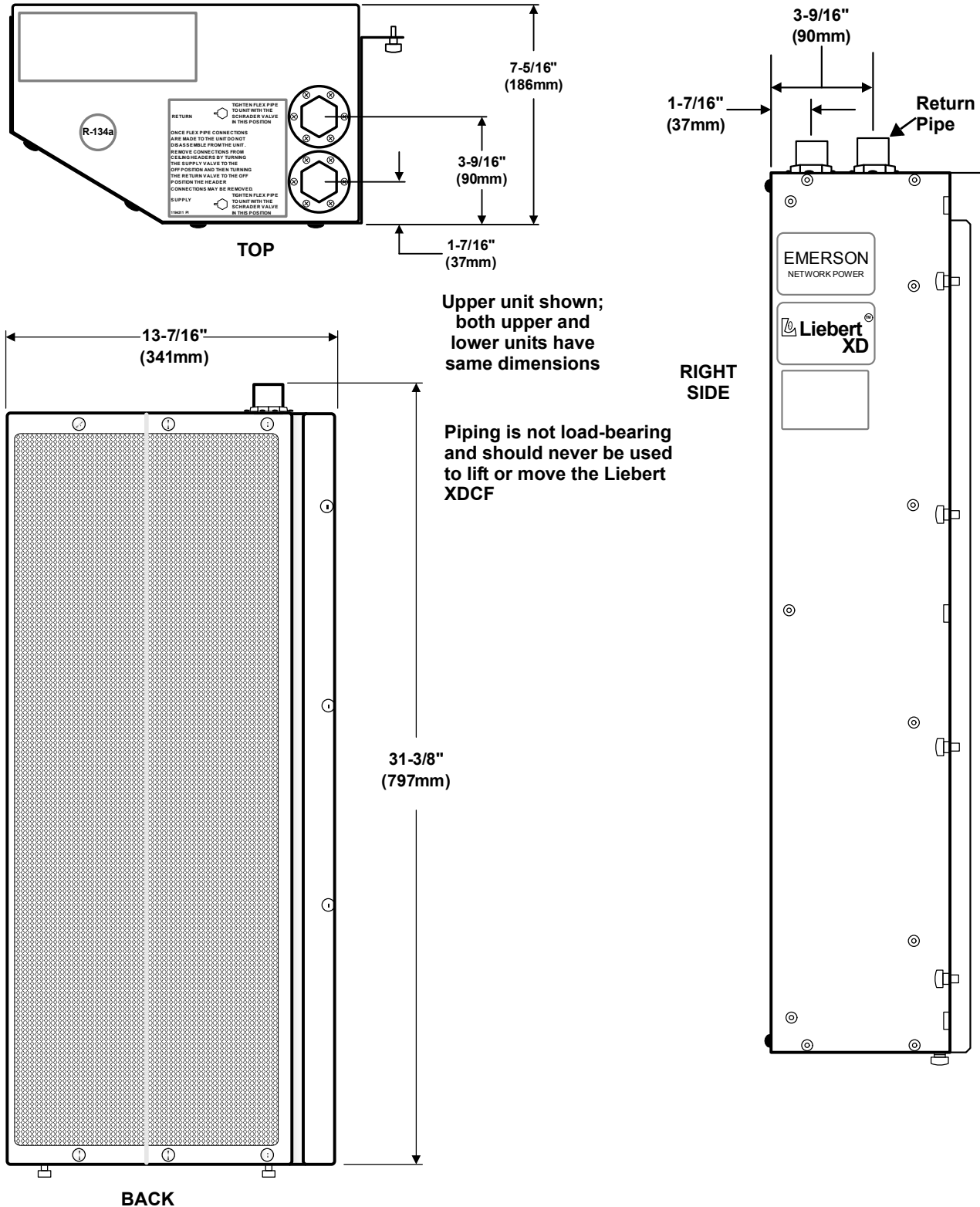

4.5 Liebert XDCF Installation Considerations

No cutting or drilling is required to attach the modules to the rear of the Egenera BladeFrame cabinet. All mounting holes, slots and pins required are fabricated at the factory.

Liebert XDCF modules attach beside the power modules on the rear of the Egenera BladeFrame (see Figure 41).

Figure 41 Liebert XDCF unit mounting locations

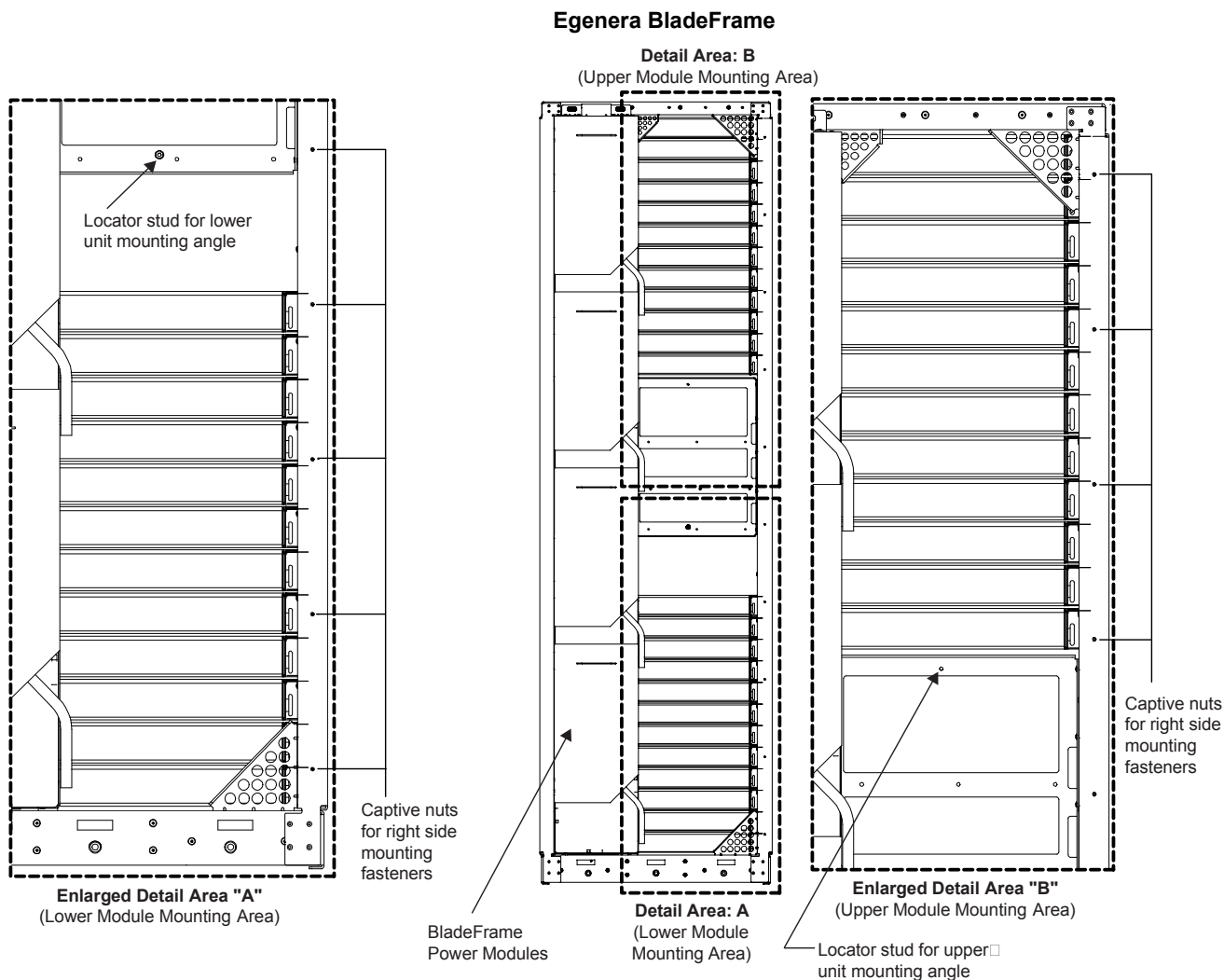

4.6 Liebert XDCF Piping Connection Methods and Points

The assembly and connection means used for piping in the Liebert XD system are the same as those used in conventional refrigeration systems. Observe all standard practices during installation and startup to prevent damage and contamination.

Supply piping connection is 1/2" OD copper pipe, and return piping connection is 5/8" OD copper. Both supply and return fittings are one-shot connections. These fittings contain pressurized R-134a refrigerant inside the Liebert XDCF.



WARNING

Risk of explosive discharge. Can cause death, injury and equipment damage.

Do not disconnect one-shot connections after they have been connected. Disconnection will release pressurized R-134a refrigerant from the Liebert XDCF.

The Liebert XDCF has supply and return piping access on the top of each module.

4.6.1 Header System

The Liebert XDCF module system requires use of the Liebert XD prefabricated piping assembly. The prefabricated piping is compatible with the flex pipe required to attach to the Liebert XDCF modules.

Figure 42 Liebert XDCF supply and return piping access points

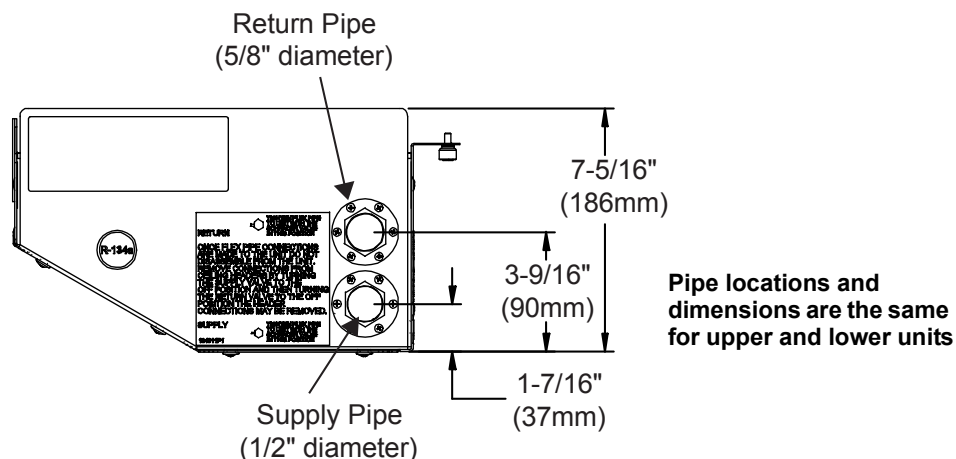

4.7 Liebert XDH Standard Features

- **Dual Refrigeration Circuits**—Each Liebert XDH has two refrigeration circuits, one in the upper half of the unit and one in the lower half. Dual refrigeration circuits permit altering cooling levels in response to server room conditions. The dual refrigeration circuits permits interlaced connection of two refrigerant sources to enhance system reliability.
- **Dual Power Cords and Power Inlets**—The Liebert XDH is supplied with two (2) detachable power cords 10 ft (3m) long that attach to two IEC power inlets on the rear of the unit. Each power cord has a NEMA 5-15P (IEC 320-C14) plug at the opposite end. The dual power cords allow the unit to be powered by two separate power sources. If the secondary power cord is connected to a UPS, the Liebert XDH unit fans will continue to operate if utility power fails.
- **Top Piping Access**—The Liebert XDH has supply and return piping access on the top of each module. Supply piping connection is 1/2" OD copper pipe, and return piping connection is 7/8" OD copper.
- **Corner Stabilizers**—A stabilizer in each corner permits rolling the Liebert XDH with greater ease and less chance of tipping.
- **Air Diffusers**—Two diffusers, one on the upper half of the unit and one on the lower half, enhance flow of cooling air. Uni-directional and bi-directional diffusers are available.

4.7.1 Optional Features—Liebert XDH

- **Condensate Detection**—A Liqui-TECT moisture detection device and a contact-closure output are available as factory-installed options. These detect condensation in the Liebert XDH's catch pan and connect to a monitoring or alarm system. A front panel alarm and indicator alert the user to condensation inside the unit.
- **Refrigerant Pre-Charge**—Liebert XDH units with the pre-charged refrigerant option will have one-shot style fittings or removable couplings that contain pressurized refrigerant inside the Liebert XDH. The fittings ease connection to Liebert XD Piping and filling with refrigerant.
- **Field-Installed Flexible Piping** (for use with prefabricated piping assemblies)—Field-installed flexible piping kits are available in lengths of 4, 6, 8 and 10 feet (1.2, 1.8, 2.4 and 3 meters). Connection style to the unit end may be straight or 90 degrees. Connection to the prefabricated piping assembly is with a threaded coupler. For information on acquiring the correct kit for your installation, refer to DPN000780, available by calling 1-800-LIEBERT and from your local Emerson Network Power representative.

Figure 43 Liebert XDH dimensions

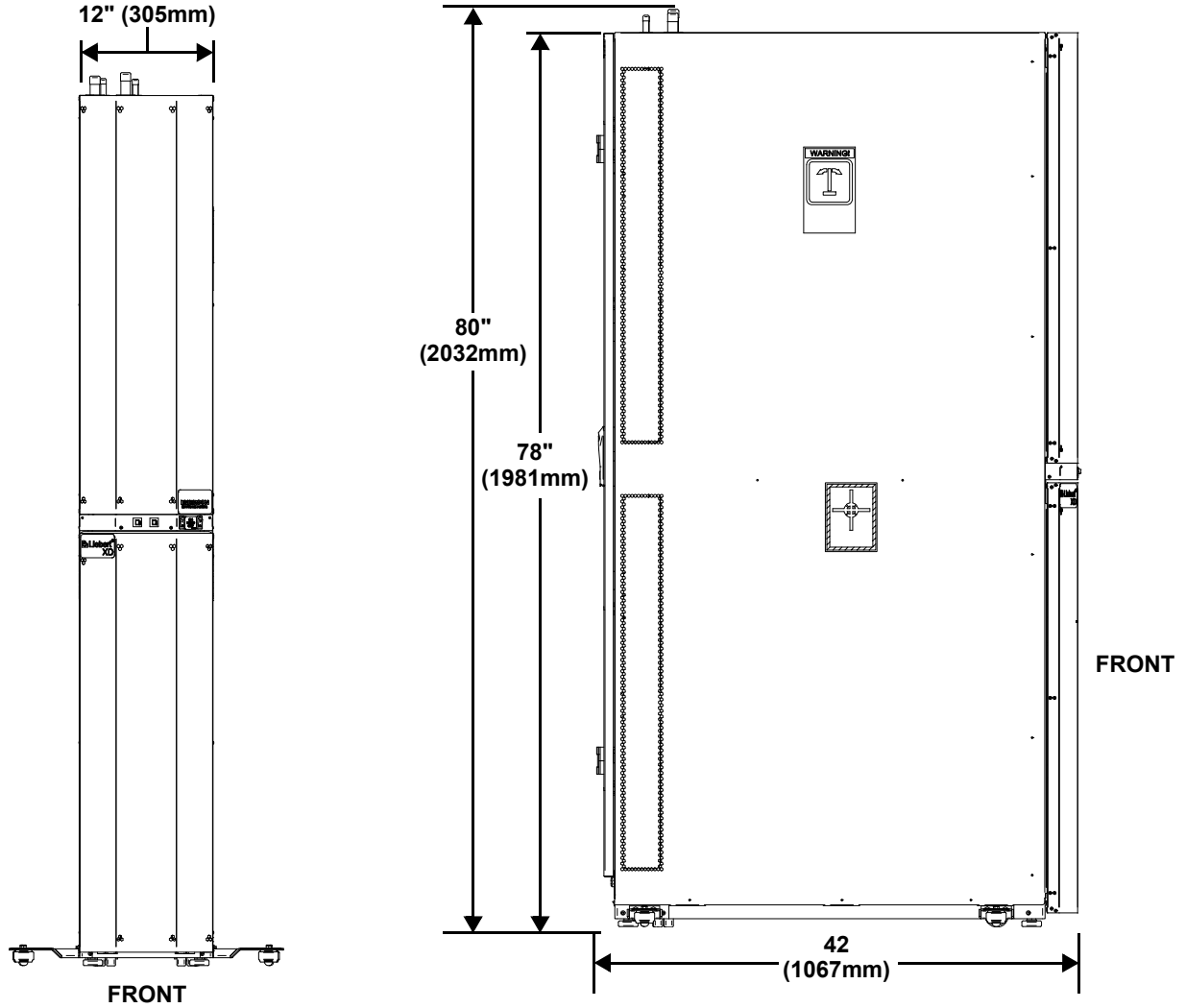
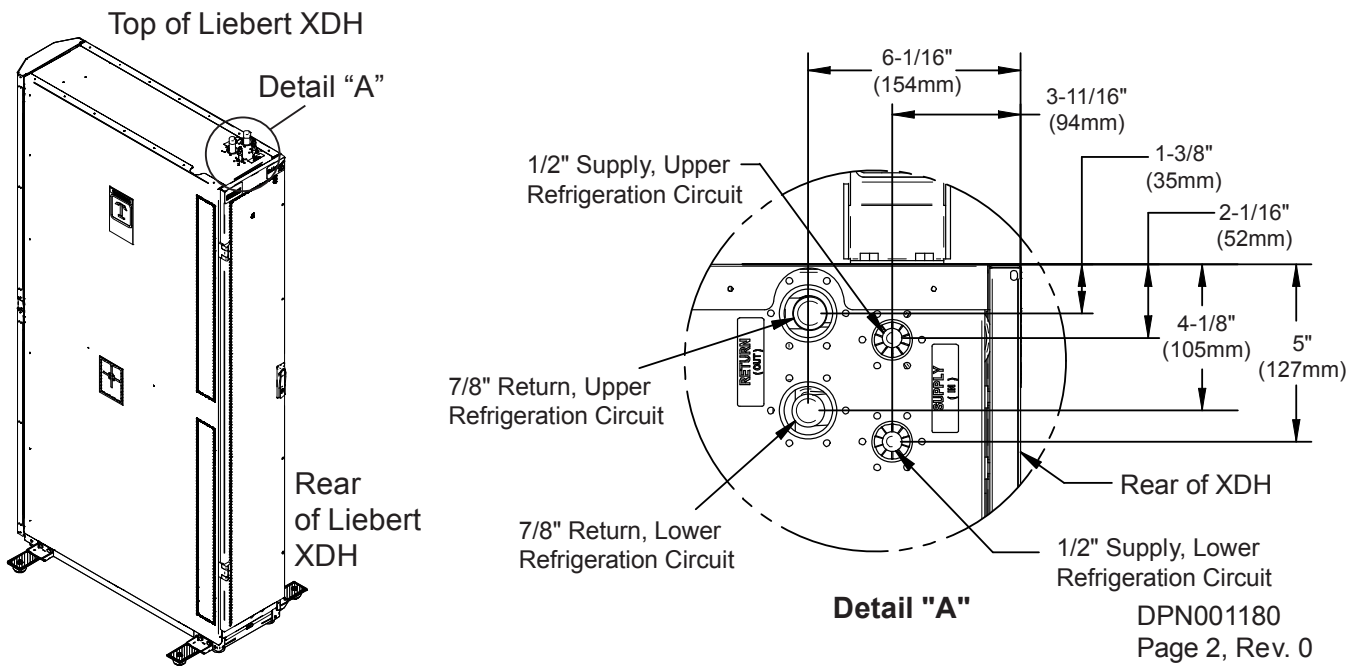

Figure 44 Supply and return piping connections



4.7.2 Piping Connections to Liebert XDP or Liebert XDC

Piping Installation for Hard Piped System

The assembly and connection means for piping in the Liebert XD system are similar to those used for conventional refrigeration systems. All piping should be installed with high-temperature brazed joints. Soft solder is not recommended. During brazing, the lines must be filled with flowing dry nitrogen to prevent excessive oxidation and scale formation inside the piping. Prevailing good refrigeration practices must be employed for piping supports, leak testing, dehydration and charging. Failure to use good system practices may result in damage to the system. Refer to the ASHRAE refrigeration handbook for general good-practice refrigeration piping.

Follow all guidelines in 3.13 - Liebert XD Piping System Design and 3.14 - Liebert XD Piping Slope during installation.

Figure 45 Hard-pipe connection diagram for Liebert XDV, Liebert XDO and Liebert XDH cooling modules

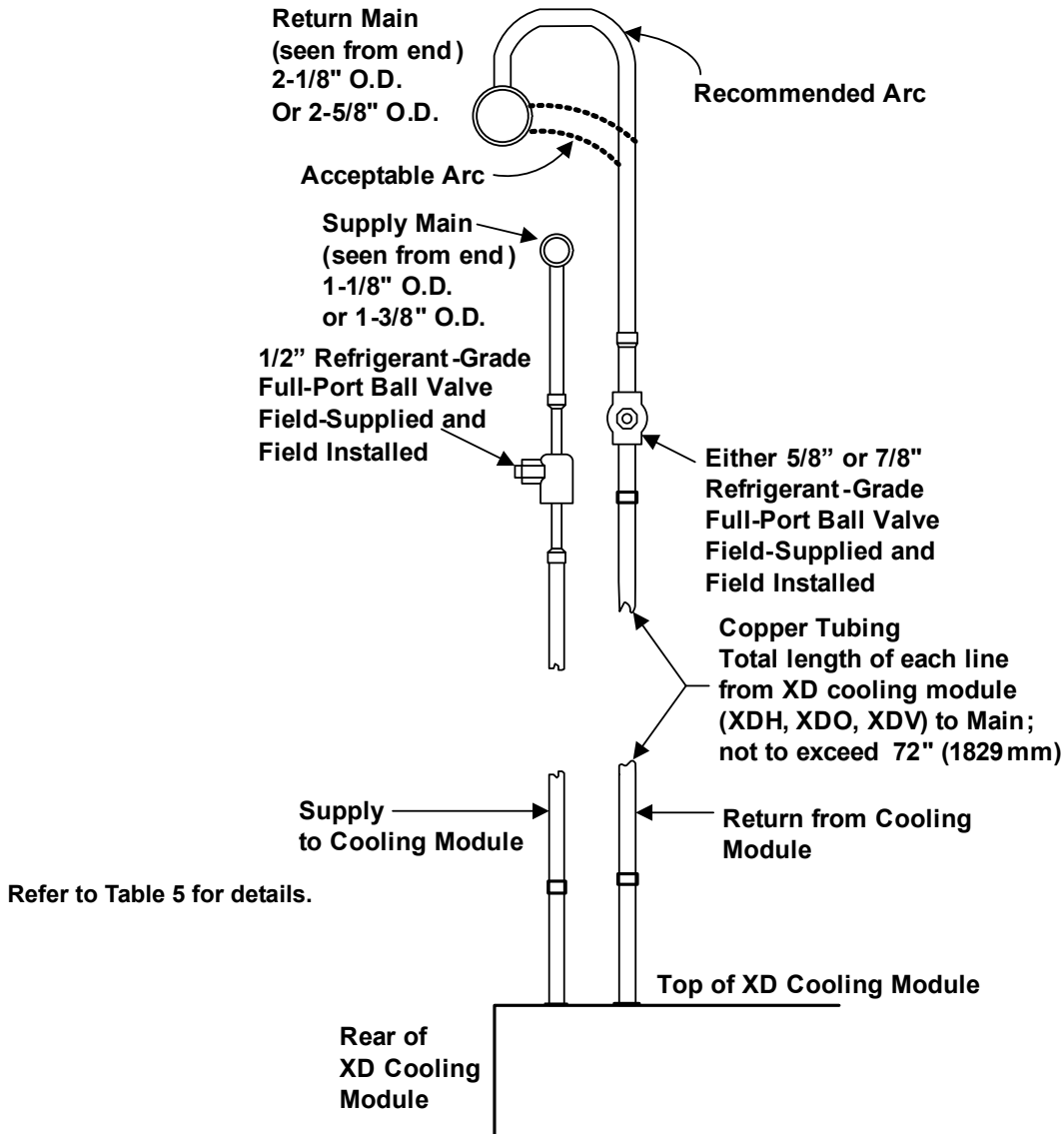

4.8 Liebert XD Flex Pipe Kit

Flex Pipe kits are available in lengths of 4, 6, 8 and 10 feet (1.2, 1.8, 2.4 and 3 meters). Connection style to the unit end may be straight or 90 degrees. Connection to the prefab piping assembly is a threaded coupler. For data on acquiring the correct kit for your installation, see **Table 17**.

Table 17 Liebert XD Flex Pipe assemblies, supply and return

Description	Liebert XDV		Liebert XD CoolFrame	Liebert XDO	Liebert XDH	
	One-shot Couplings	Removable Couplings	One-shot Couplings	One-shot Couplings	One-shot Couplings	Removable Couplings
4ft long (1.2m), 0°	186568G4	187867G4	186568G4 ²	186566G4	2 x 186566G4	2 x 187865G4
4ft long (1.2m), 90°	186567G4	187866G4	-	186565G4	2 x 186565G4	2 x 187864G4
6ft long (1.8m), 0°	186568G1	187867G1	186568G1 ²	186566G1	2 x 186566G1	2 x 187865G1
6ft long (1.8m), 90°	186567G1	187866G1	-	186565G1	2 x 186565G1	2 x 187864G1
8ft long (2.5m), 0°	186568G3	187867G3	186568G3 ³	186566G3	2 x 186566G3	2 x 187865G3
8ft long (2.5m), 90°	186567G3	187866G3	-	186565G3	2 x 186565G3	2 x 187864G3
10ft long (10m), 0°	186568G2	187867G2	186568G2 ³	186566G2	2 x 186566G2	2 x 187865G2
10ft long (10m), 90°	186567G2	187866G2	-	186565G2	2 x 186565G2	2 x 187864G2
Min Bend Radius, Supply ¹	7" (178mm)			7" (178mm)		
Min Bend Radius, Return ¹	8" (203mm)			9" (229mm)		

1. The minimum bend radius is for the flexible portion of the Liebert XD Flex Pipe. Because a section of hard pipe is at each end of the Liebert XD Flex Pipe, the minimum bend radius can be larger.
2. Top Module
3. Bottom Module

4.9 Liebert XD Piping Dimensions and Features

4.9.1 Piping Installation Method prefabricated headers

The assembly and connection means used for piping in the Liebert XD system are similar to those used for conventional refrigeration systems. All piping should be installed with high-temperature brazed joints. Soft solder is not recommended. During brazing, the lines must be filled with flowing dry nitrogen to prevent excessive oxidation and scale formation inside the piping. Prevailing good refrigeration practices must be employed for piping supports, leak testing, dehydration and charging. Failure to use good system practices may result in damage to the system. Refer to the ASHRAE refrigeration handbook for general good-practice refrigeration piping.

Follow all guidelines in 3.13 - Liebert XD Piping System Design and 3.14 - Liebert XD Piping Slope during installation.

Figure 46 Two-port prefabricated piping for Liebert XD cooling modules

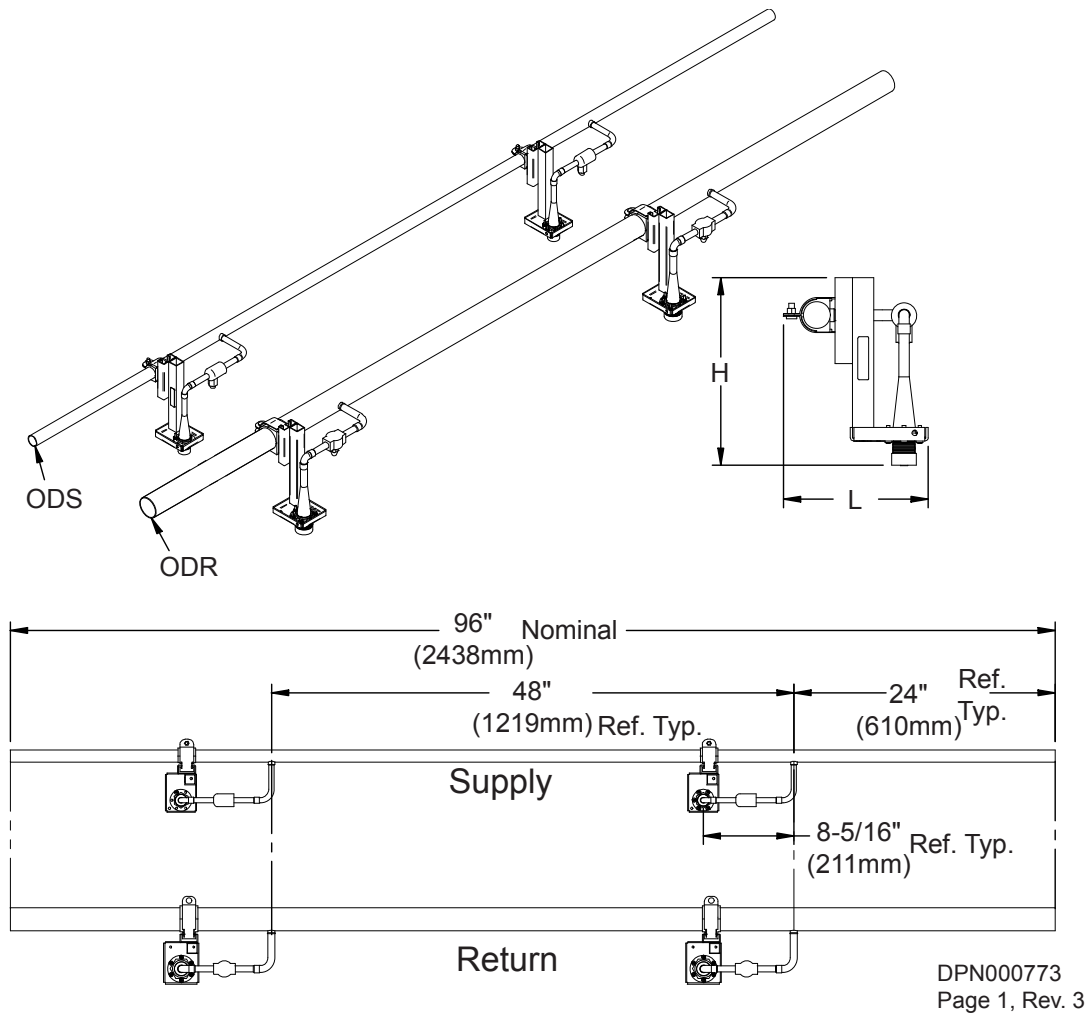

Table 18 Two-port prefabricated piping legend

Branch Piping		Standard Run	Long Run *
Two Port		185797G21	185800G21
Supply inch (mm)	Outside Diameter (ODS)	1-1/8	1-3/8
	Height (H)	8-3/4 (222)	8-3/4 (222)
	Length (L)	6-3/4 (171)	6-7/8 (175)
Return inch (mm)	Outside Diameter (ODR)	2-1/8	2-5/8
	Height (H)	10-1/2 (267)	10-1/2 (267)
	Length (L)	8-3/4 (222)	9-1/8 (232)

* Pipe runs greater than 60 equivalent feet

Figure 47 Four-port prefabricated piping for Liebert XD cooling modules

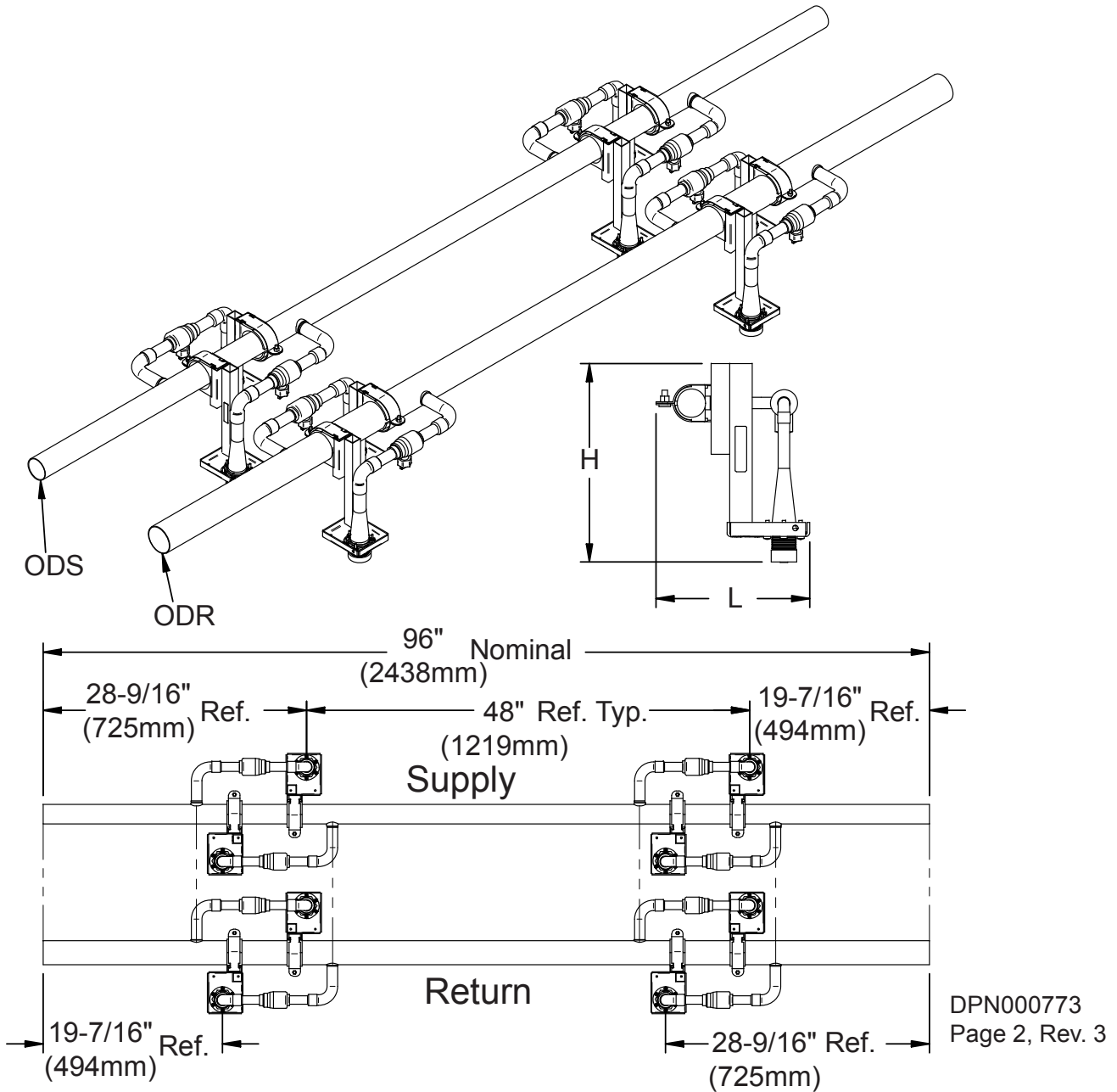
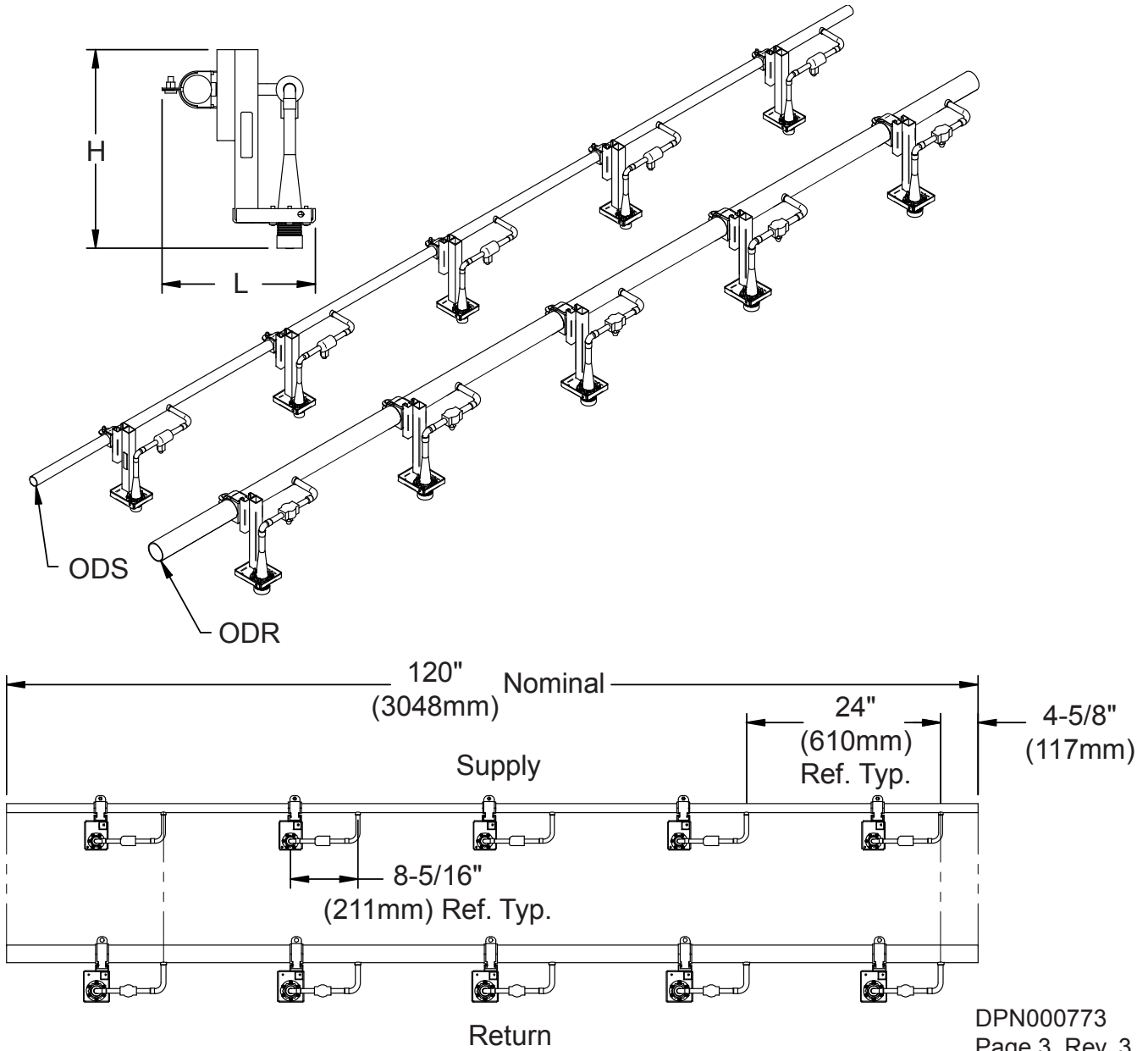

Table 19 Four-port prefabricated piping legend

Branch Piping		Standard Run	Long Run *
Four Port		186551G21	186552G21
Supply inch (mm)	Outside Diameter (ODS)	1-1/8	1-3/8
	Height (H)	8-3/4 (222)	8-3/4 (222)
	Length (L)	6-3/4 (171)	6-7/8 (175)
Return inch (mm)	Outside Diameter (ODR)	2-1/8	2-5/8
	Height (H)	10-1/2 (267)	10-1/2 (267)
	Length (L)	8-3/4 (222)	9-1/8 (232)

* Pipe runs greater than 60 equivalent feet

Figure 48 Five-port prefabricated piping for Liebert XD cooling modules



DPN000773
Page 3, Rev. 3

Table 20 Five-port prefabricated piping legend

Branch Piping		Standard Run	Long Run *
Five Port		185797G51	185800G51
Supply inch (mm)	Outside Diameter (ODS)	1-1/8	1-3/8
	Height (H)	8-3/4 (222)	8-1/2 (216)
	Length (L)	6-3/4 (171)	7 (178)
Return inch (mm)	Outside Diameter (ODR)	2-1/8	2-5/8
	Height (H)	10-1/2 (267)	10-1/2 (267)
	Length (L)	8-3/4 (222)	9-1/8 (232)

* Pipe runs greater than 60 equivalent feet

Figure 49 Ten-port prefabricated piping for Liebert XD cooling modules

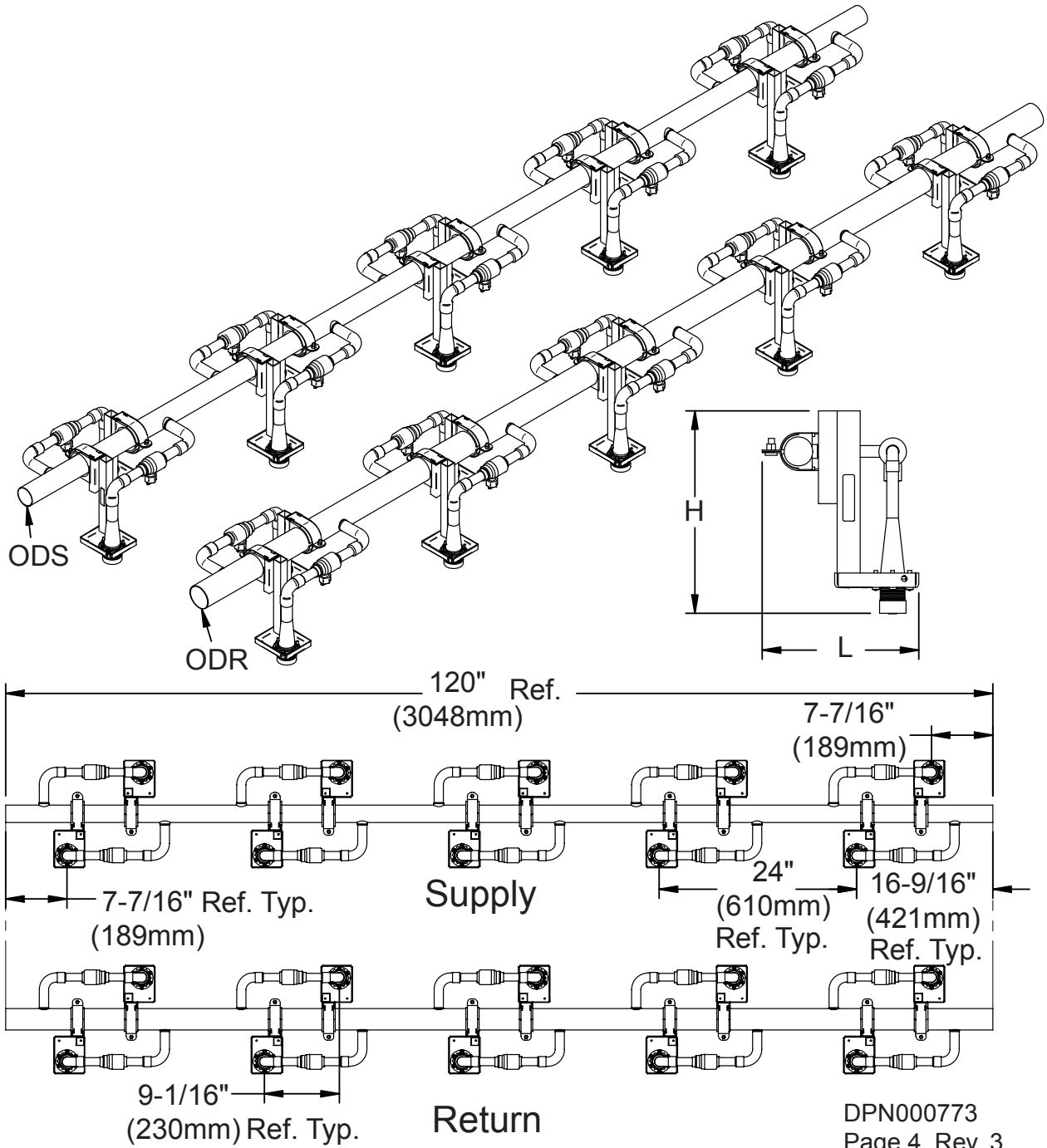

Table 21 Ten-port prefabricated piping legend

Branch Piping		Standard Run	Long Run *
Ten Port		186650G51	186553G51
Supply inch (mm)	Outside Diameter (ODS)	1-1/8	1-3/8
	Height (H)	8-3/4 (222)	8-3/4 (222)
	Length (L)	6-3/4 (171)	6-7/8 (175)
Return inch (mm)	Outside Diameter (ODR)	2-1/8	2-5/8
	Height (H)	10-1/2 (267)	10-1/2 (267)
	Length (L)	8-3/4 (222)	9-1/8 (232)

* Pipe runs greater than 60 equivalent feet

4.10 Liebert XDP Standard Features

- Heat Exchanger—Brazed plate design with interwoven circuiting constructed of stainless steel plates, copper brazed.
- Pumps—Centrifugal type, end suction, internally cooled, canned rotor design.
- Standard Control Processor—The standard control system is microprocessor-based with an external LCD numerical display to allow observation of specified adjustable functions. Operating conditions and status are indicated on the LCD panel, which is mounted either on the unit or on the wall, depending on application details (see user manual, SL-16641). The control system also monitors unit operation and activates an alarm when any of the specified factory preset conditions are exceeded.
- Cabinet and Frame—Custom powder painted steel panels. A hinged control access panel opens to a second front panel, which is a protected enclosure for all high voltage components. Frame is constructed of 14 gauge heliarc welded tubular steel and painted using an auto-deposition coating system.

Figure 50 Liebert XDP dimensions

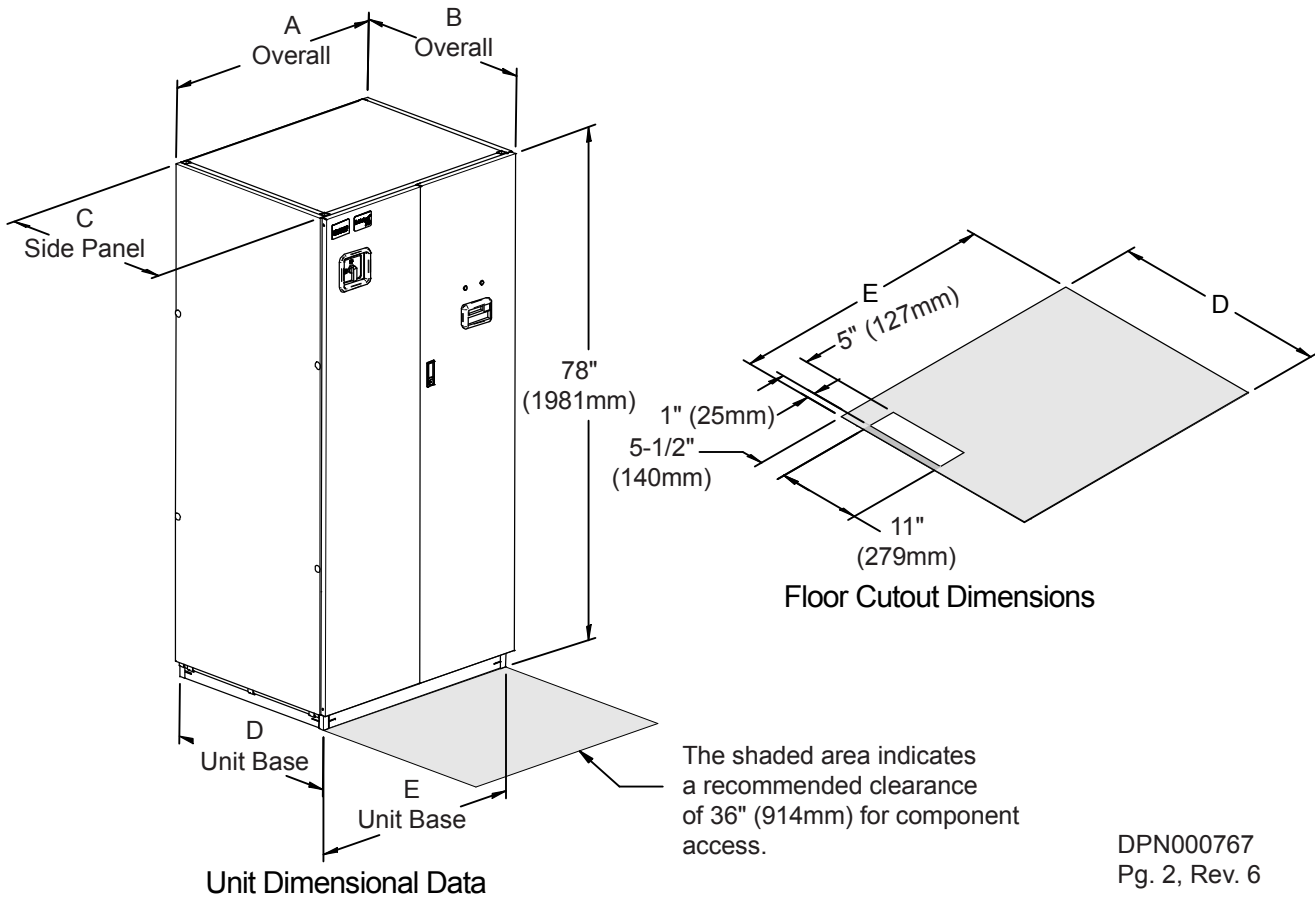
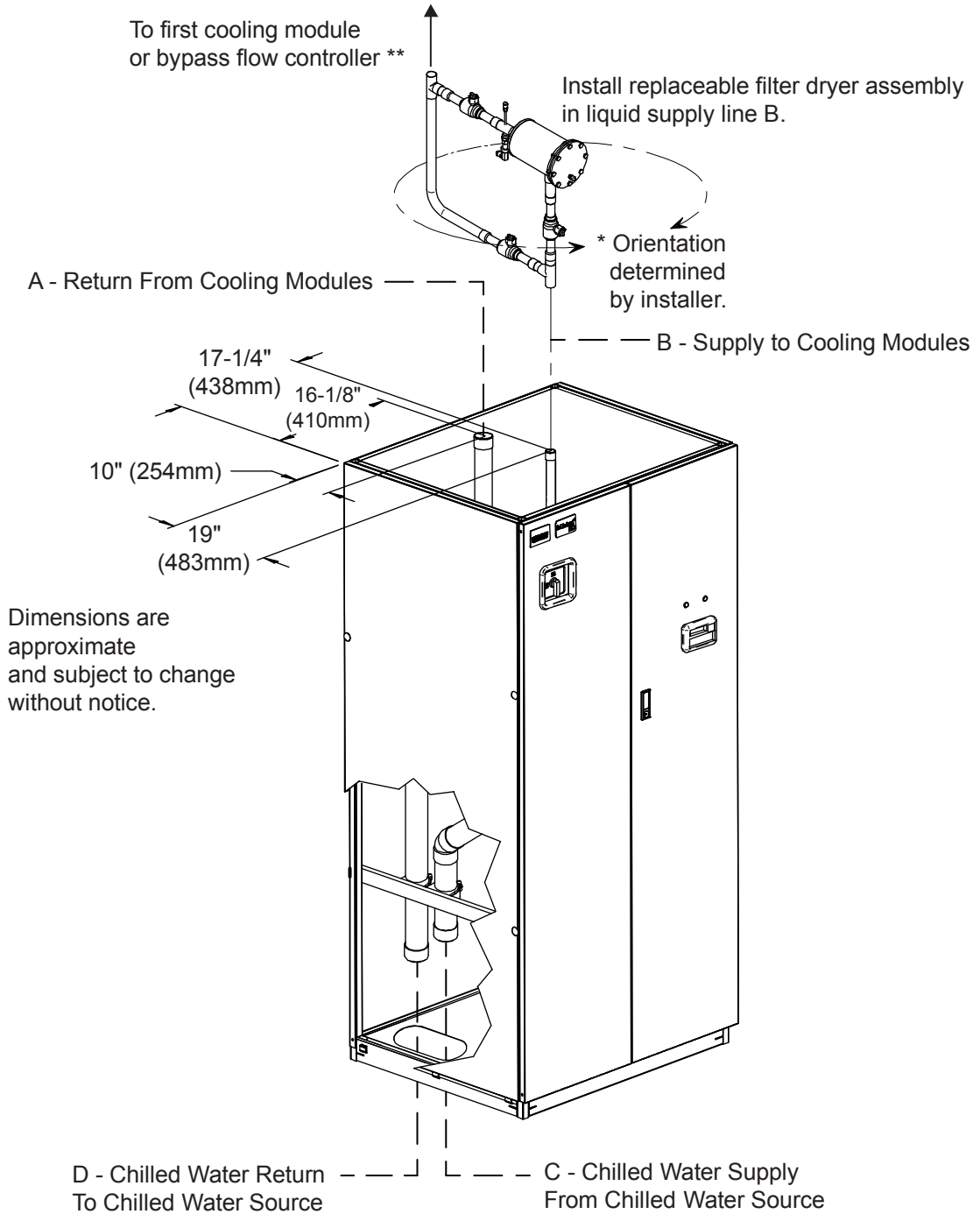

Table 22 Liebert XDP dimensions

Model 50/60Hz	Dimensional Data inches (mm)					Shipping Weight, lb (kg)	
	A	B	C	D	E	Domestic	Export
Liebert XDP160	38 (965)	34 (864)	33-1/8 (841)	33 (838)	36 (914)	990 (449)	1067 (484)

* The dimension does not include the bezel of the disconnect switch.

Figure 51 Liebert XDP piping access points and external features



* Allow 8" (204mm) clearance for filter replacement.

** To ensure ensure all refrigerant flow is filtered, install the filter dryer assembly between the discharge line of the XDP and the first bypass flow controller or the first cooling module.

DPN000767
Pg. 3, Rev. 6

Table 23 Unit piping outlet connection sizes, inches, OD Cu

Model	Pipe Connection Point			
	A	B	C	D
Liebert XDP160	2-1/8	1-1/8	2-5/8	2-5/8

Figure 52 Front view of Liebert XDP and electrical enclosure

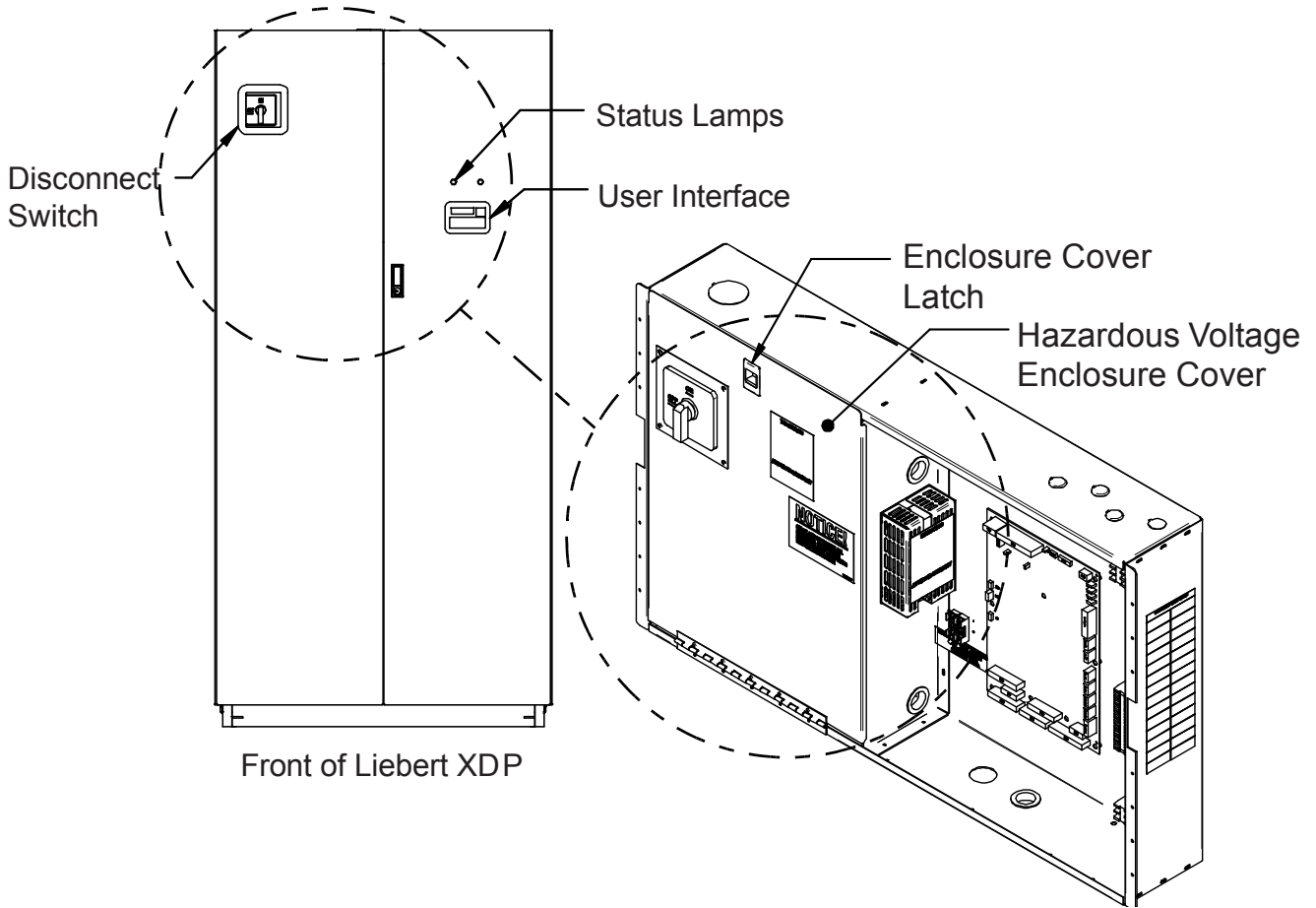

Figure 53 Liebert XDP electrical enclosure knockout locations for field wiring

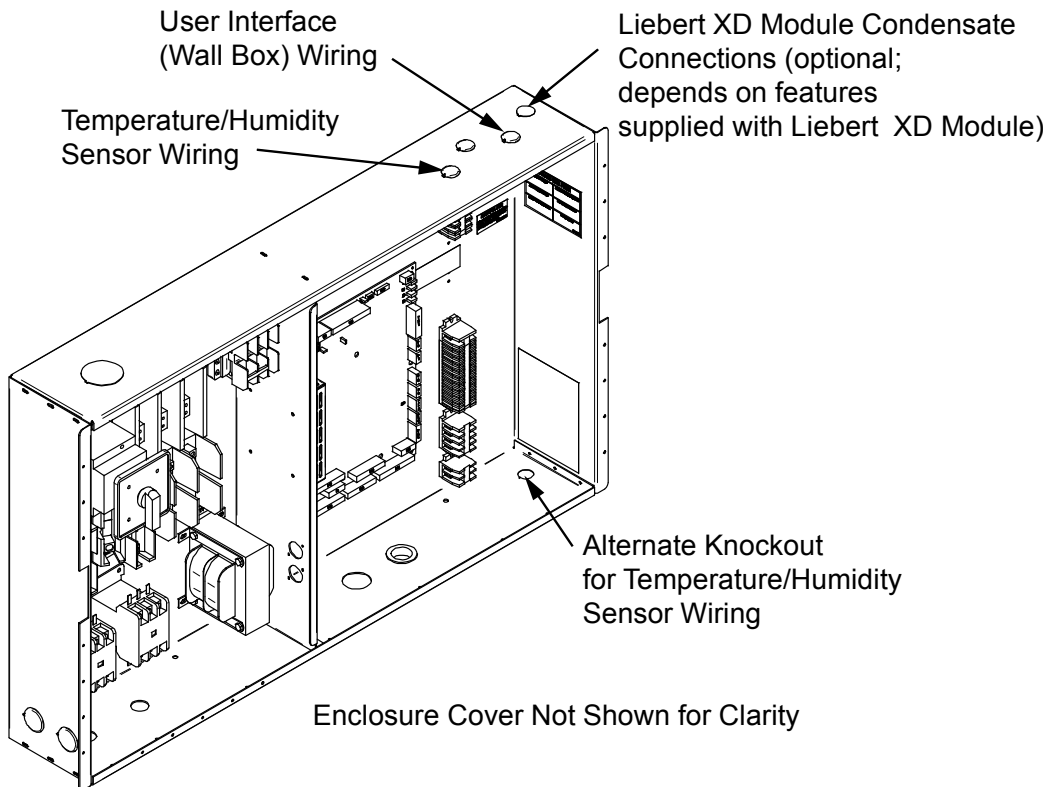

Figure 54 Liebert XDP 60Hz high voltage connections

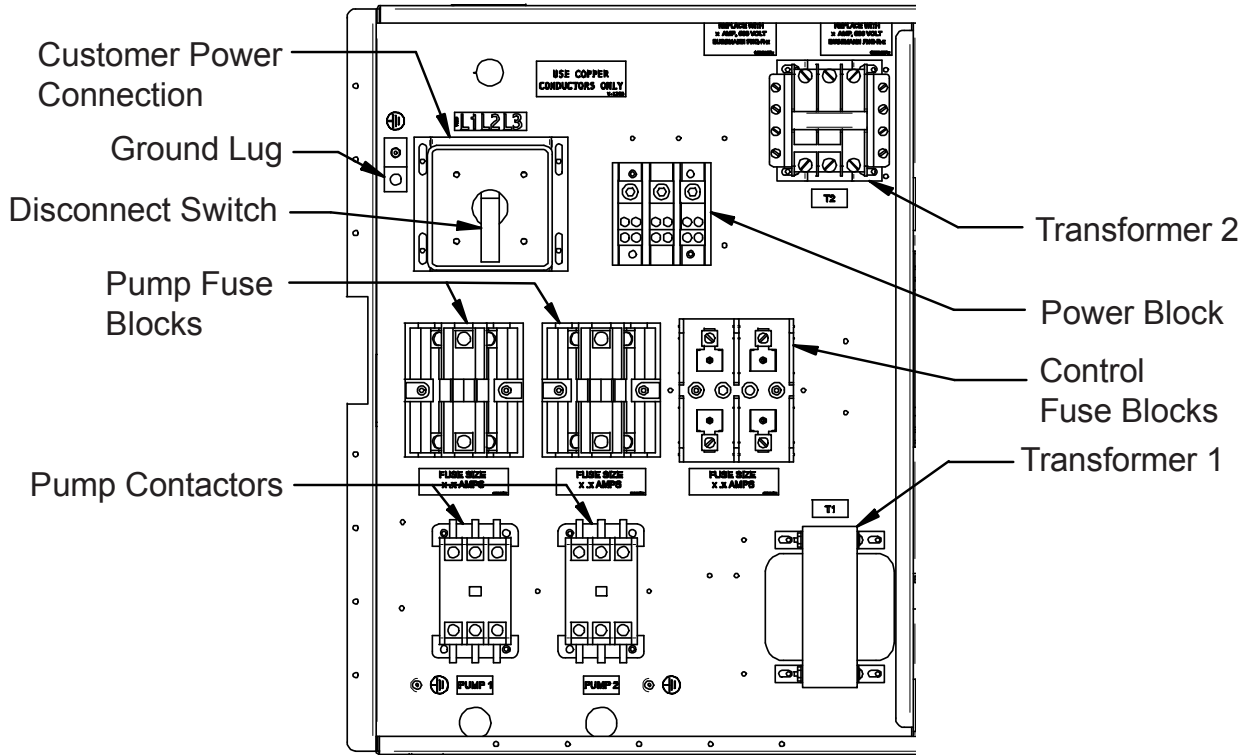
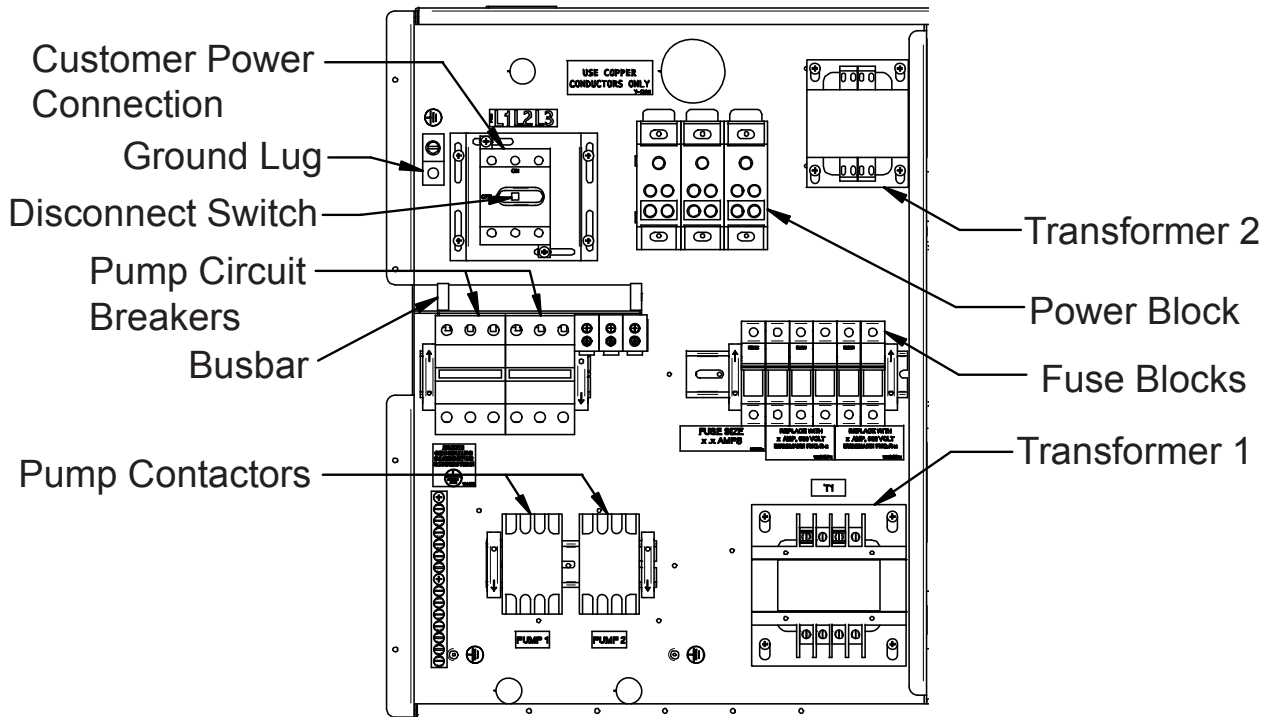

Figure 55 Liebert XDP 50Hz high voltage connections



4.11 Liebert XDC Standard Features

- Compressors—Scroll with a suction gas cooled motor, vibration isolators, thermal overloads, manual reset high-pressure switch and pump down low-pressure switch.
- Refrigeration System—Dual refrigeration circuits each including liquid line filter dryers, refrigerant sight glass with moisture indicator, electronic control valve, adjustable externally equalized expansion valves and liquid line solenoid valves.
- Heat Exchanger—Brazed plate design with interwoven circuiting constructed of stainless steel plates, copper brazed. PUMPS Centrifugal type, end suction, canned rotor design.
- Standard Control Processor—The standard control system is microprocessor-based with an external LCD numerical display to allow observation of specified adjustable functions. Normal operating conditions are indicated on the LCD panel, which is mounted either on the unit or on the wall, depending on application details (see user manual, SL-16671). The control system also monitors unit operation and activates an alarm when any of the specified factory preset conditions are exceeded.
- Cabinet and Frame—Custom powder painted steel panels. A hinged control access panel opens to a second front panel, which is a protected enclosure for all high voltage components. Frame is constructed of 14 gauge heliarc welded tubular steel and painted using an auto-deposition coating system.

4.11.1 Liebert XDC Optional Features

- Water / Glycol Condensers—A water/glycol floor stand condenser option is available for heat rejection requirements. The water/glycol floor stand can be located beneath the XDC unit or installed nearby.

Figure 56 Liebert XDC dimensional data

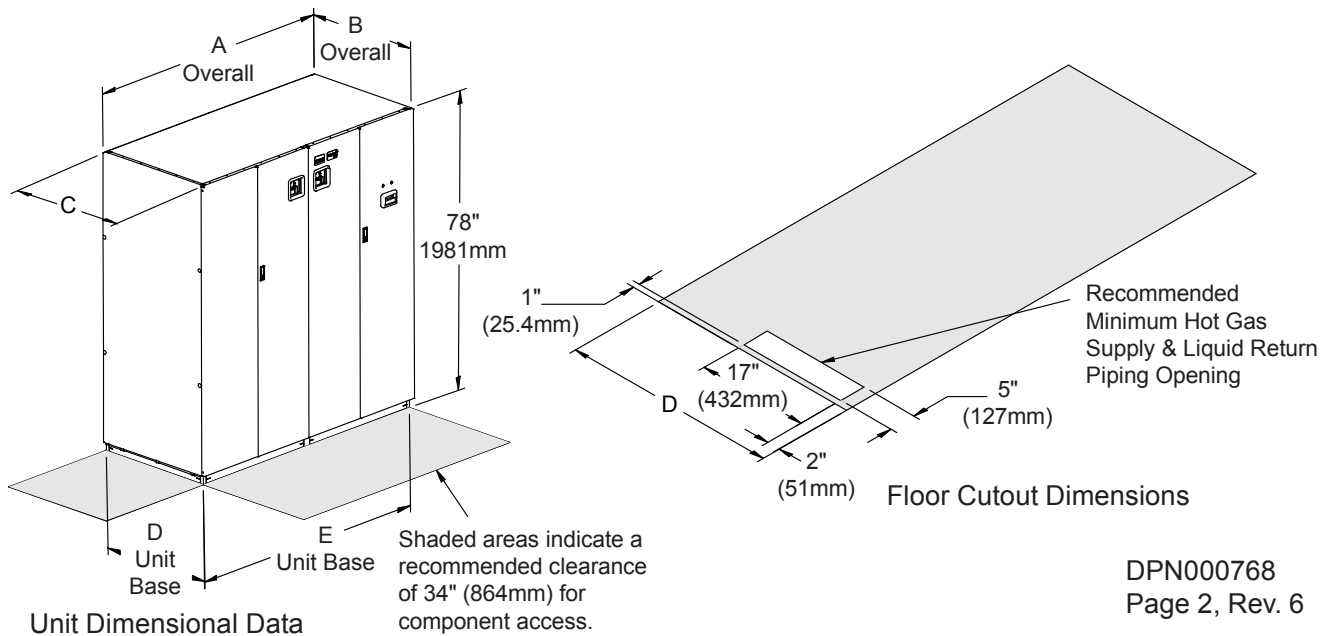
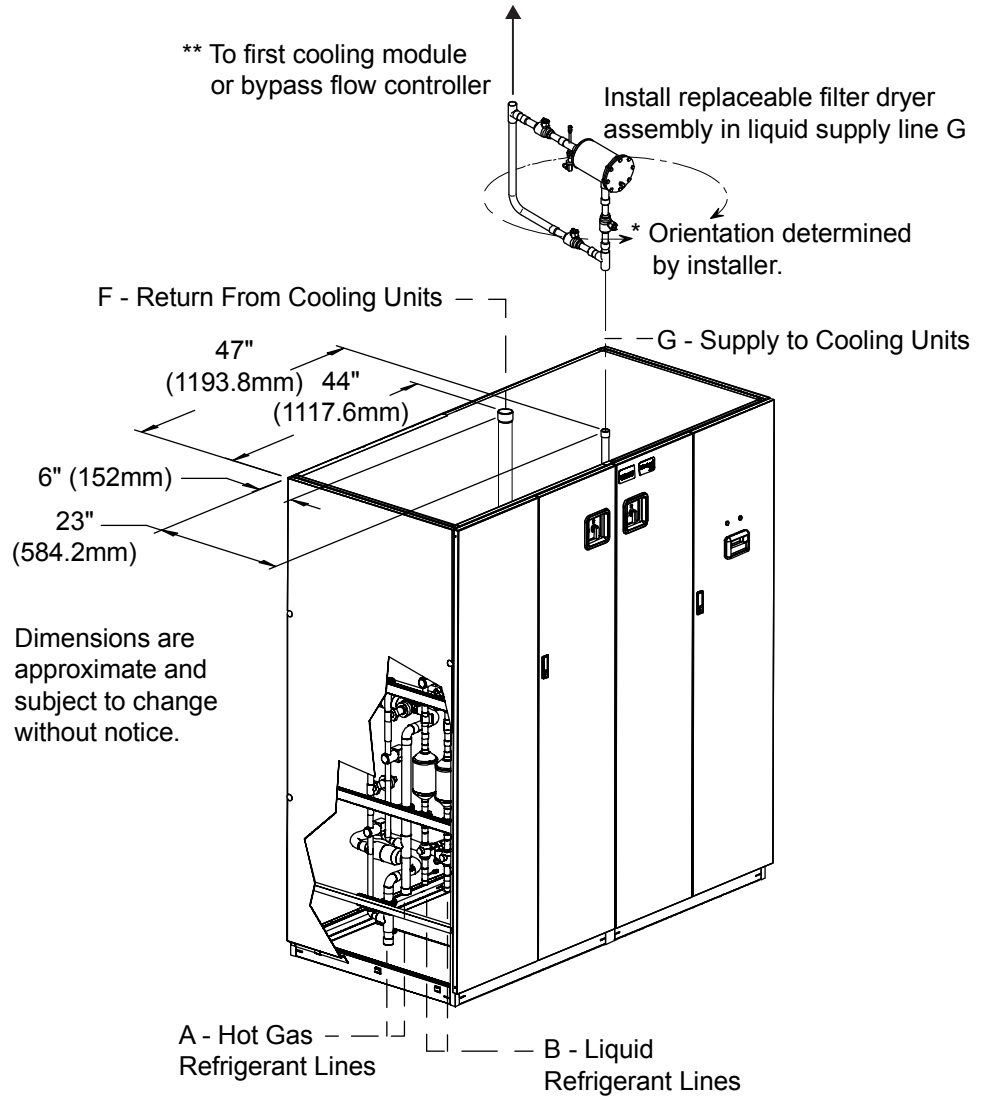

Table 24 Liebert XD Chiller dimensions, weight

Air Cooled Model	Dimensional Data, inches (mm)					Shipping Weight, lb (kg)	
	A	B	C	D	E	Domestic	Export
Liebert XDC160	74 (1880)	34 (864)	33-1/8 (841)	33 (838)	72 (1829)	1945 (882)	2093 (949)

* Dimension does not include the bezel of the disconnect switch.

Figure 57 Liebert XDC piping locations



* Allow 8" (204mm) of clearance for filter replacement

** To ensure all refrigerant flow is filtered, install the filter dryer assembly between the discharge line of the XDC and the first bypass flow controller or the first cooling module.

DPN000768
Page 3, Rev. 6

Table 25 Liebert XD Chiller piping connection sizes

Air Cooled Models	Piping Outlet Connection Sizes, OD Cu, inches						
	A	B	C	D	E	F	G
50/60Hz							
Liebert XDC160	1-3/8	7/8	-	-	-	2-1/8	1-1/8

Figure 58 Positioning a water/glycol Liebert XDC for placement on a floor stand

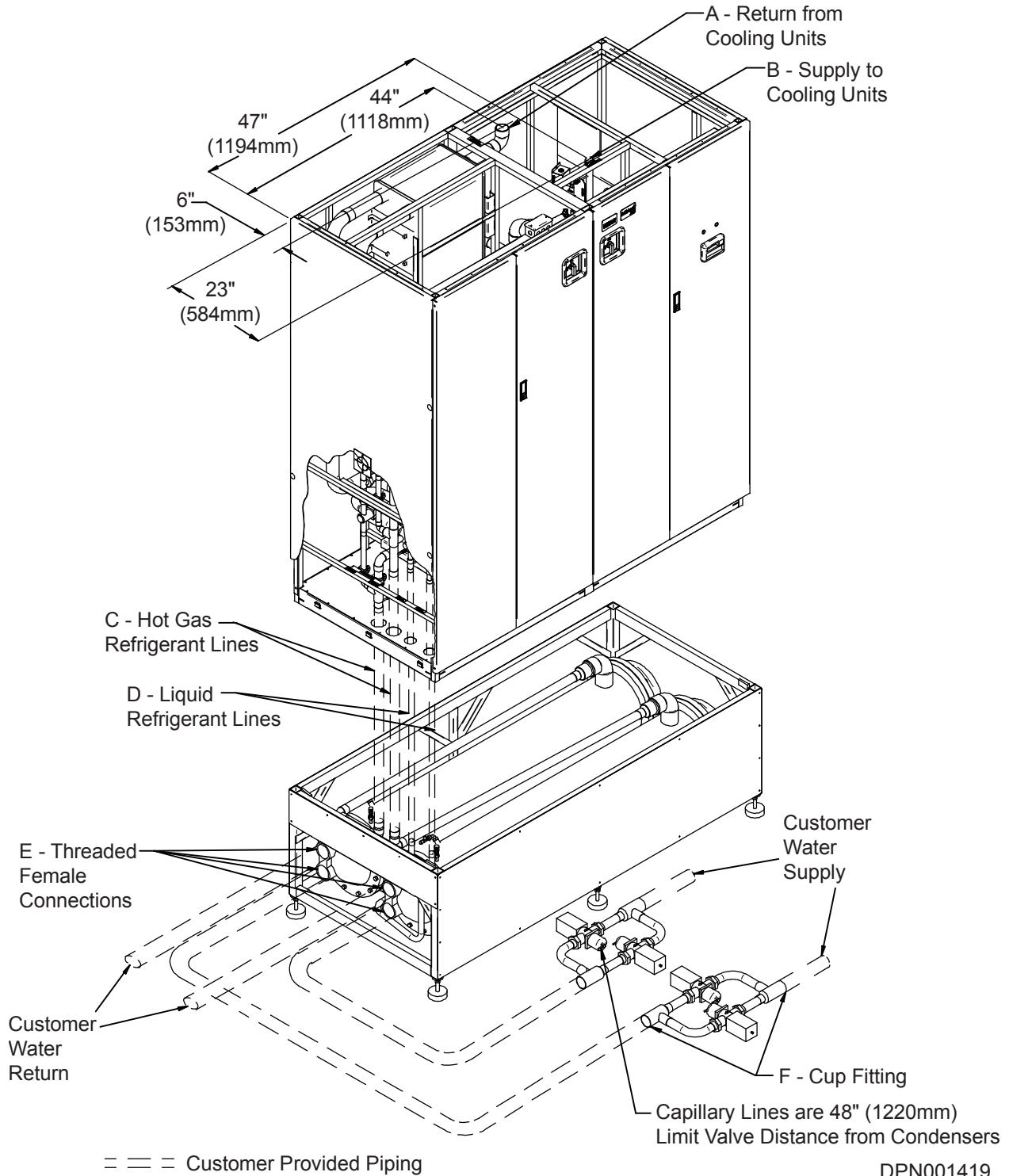

DPN001419
Pg. 01, Rev. 01

Table 26 Liebert XDC Water/Glycol Piping Connection Sizes

Model	Piping Outlet Connection Sizes, OD Cu, inches					
50/60Hz	A	B	C	D	E*	F**
XDC160	2-1/8	1-1/8	1-3/8	7/8	2-1/2	2-1/8 or 2-5/8

* Threaded Female Connection

** 2-1/8" for 1" WRV, 2-5/8" for 1-1/4" WRV

Figure 59 Piping locations—floor stand and valve assembly

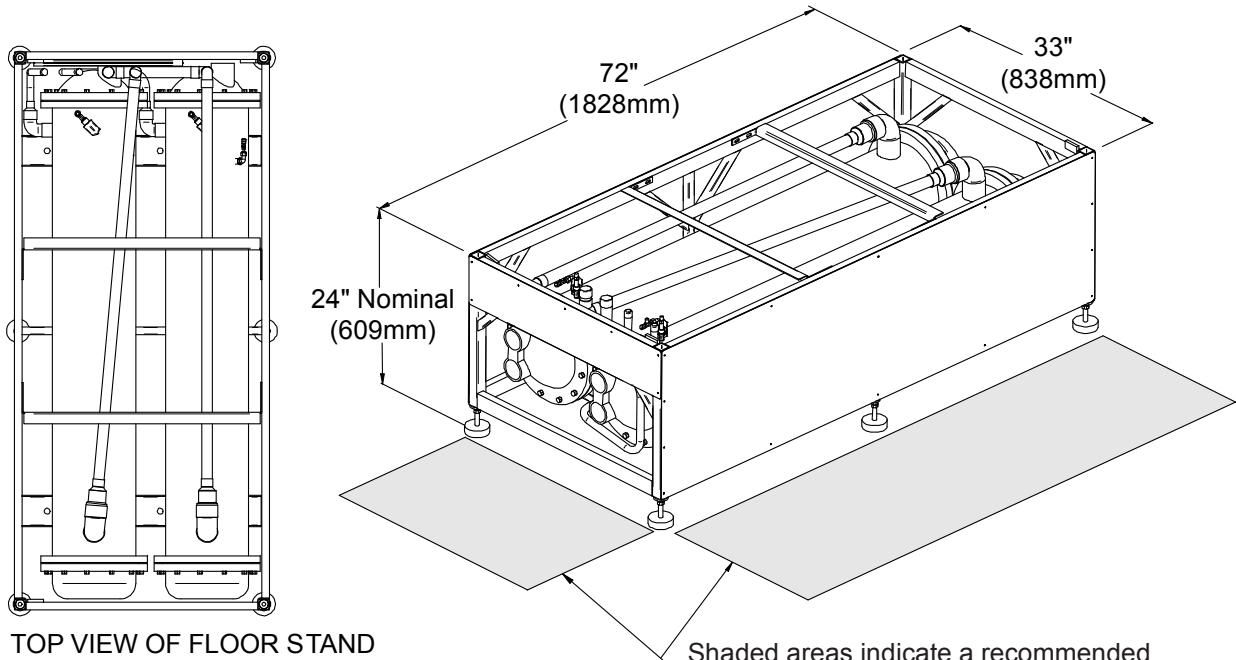

TOP VIEW OF FLOOR STAND

Shaded areas indicate a recommended clearance of 36" (915mm) for component access and water/glycol piping.

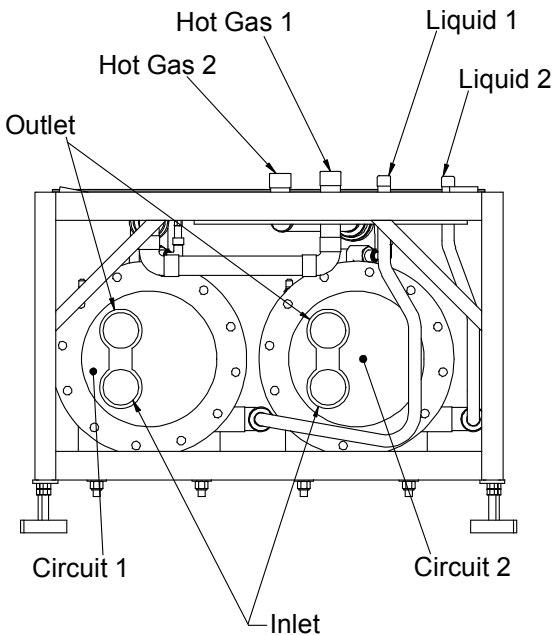

FLOOR STAND CONNECTIONS

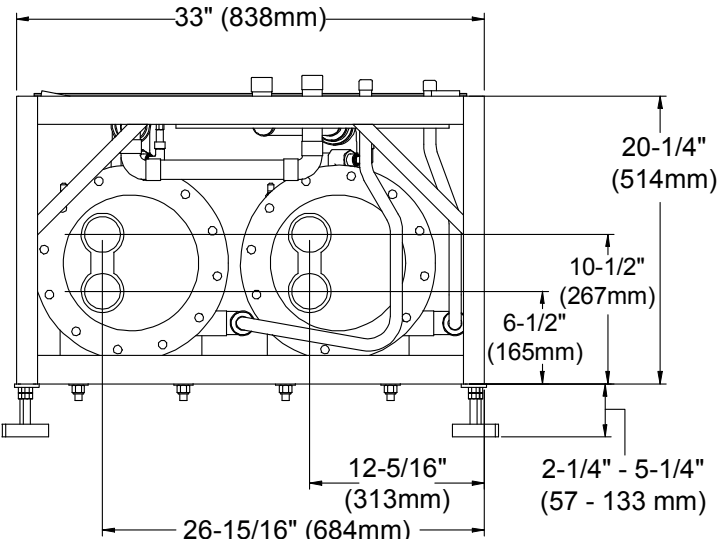

LEFT SIDE OF CABINET

DPN001419
Pg. 2 , Rev. 01

Figure 60 Front view of Liebert XDC and electrical enclosures

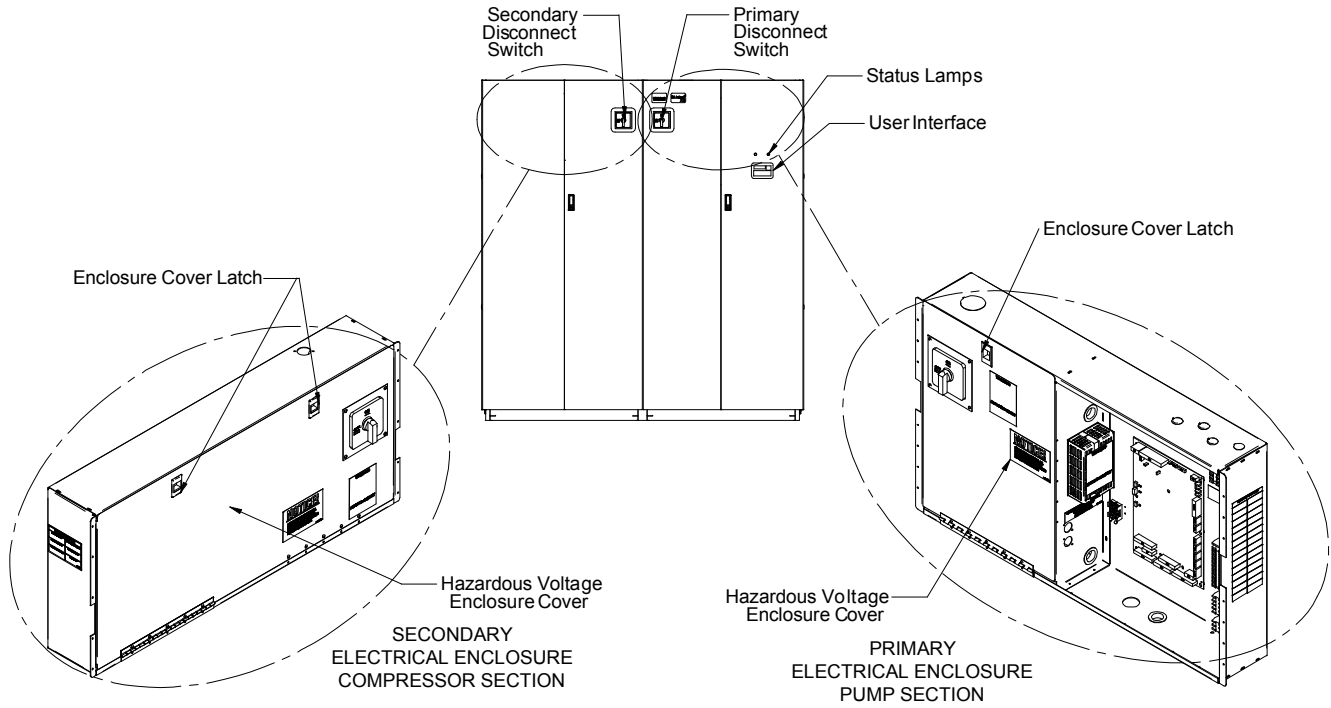

Figure 61 Liebert XDC electrical enclosure knockout locations for field wiring

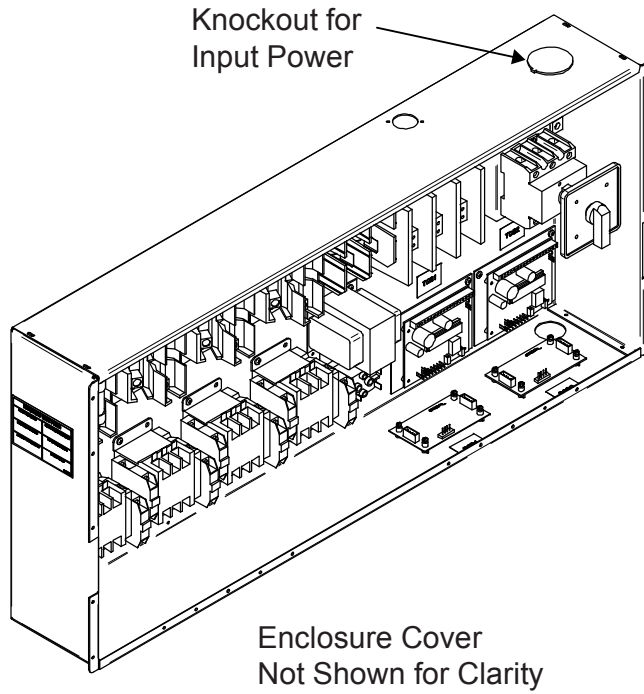

Figure 62 Liebert XDC high voltage connections—primary disconnect switch, 60Hz models

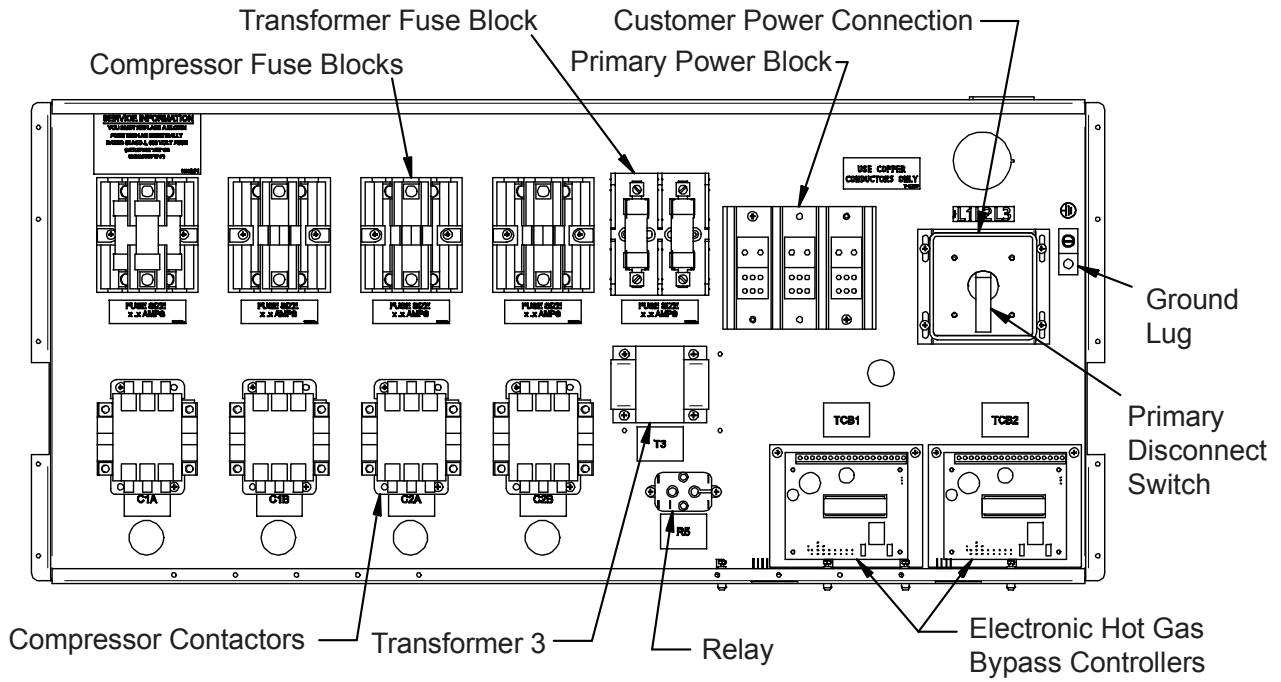

Figure 63 Liebert XDC high voltage connections—primary disconnect switch, 50Hz models

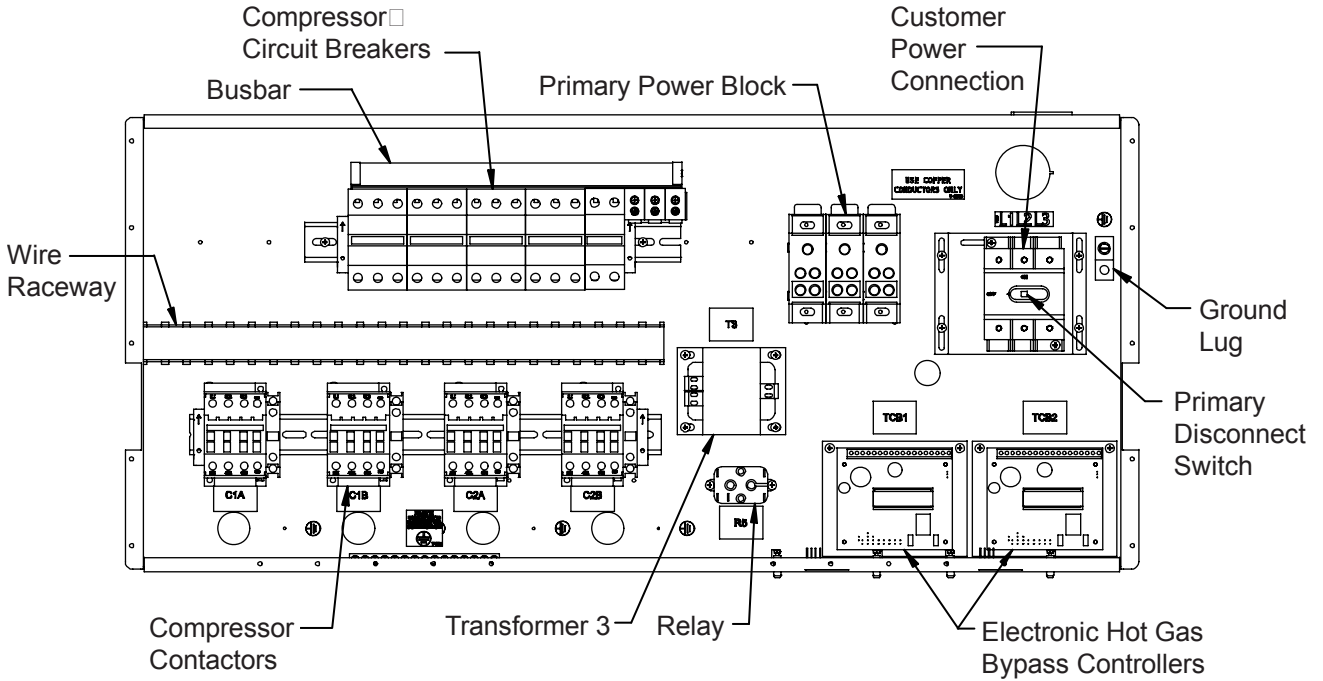

Figure 64 Liebert XDC high voltage connections—secondary disconnect switch, 60Hz models

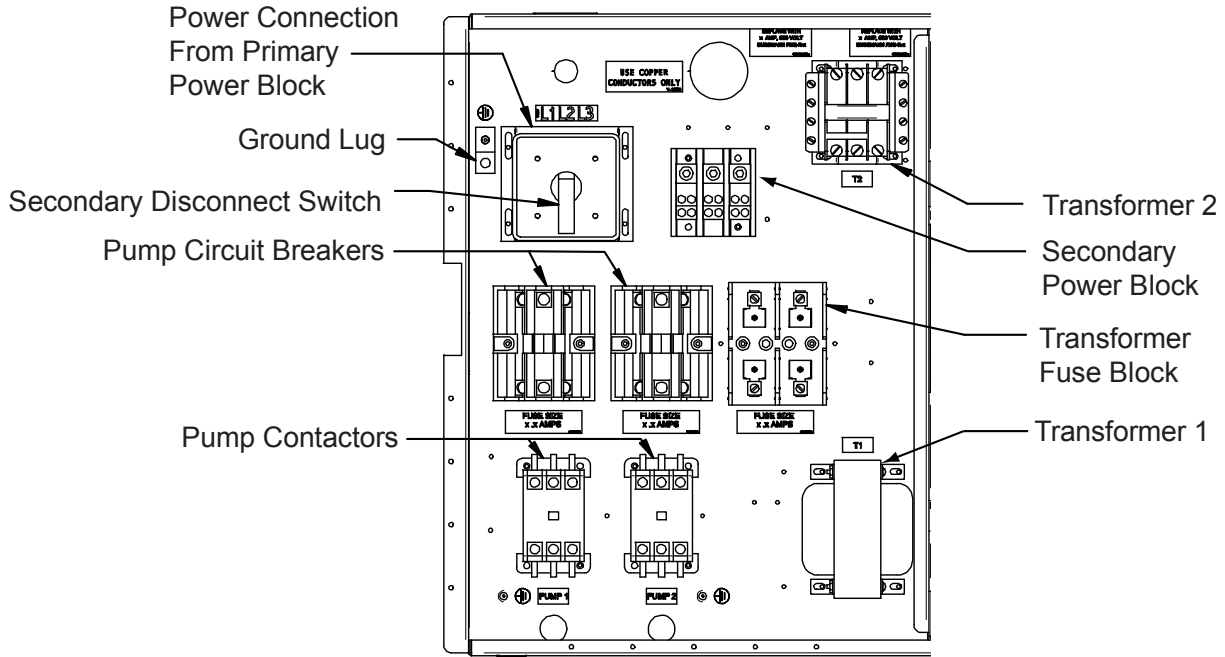

Figure 65 Liebert XDC high voltage connections—secondary disconnect switch, 50Hz models

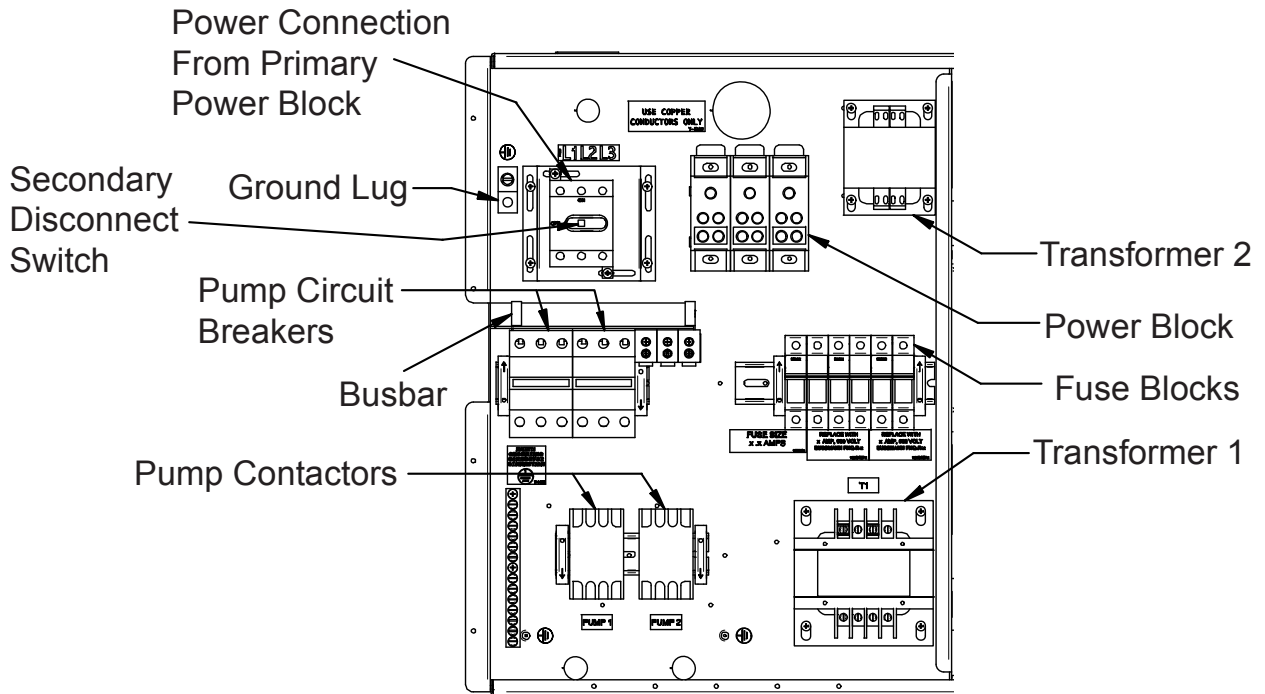

Figure 66 Liebert XDC heat rejection electrical connection points

HEAT REJECTION ELECTRICAL CONNECTION POINTS
Field-supplied 24V. Class 1 wiring to interlock heat rejection from pigtails:
70A and 71A - Compressor 1 circuit
70B and 71B - Compressor 2 circuit
70C and 71C - Dual Source relay (optional)

Electrical handy box, factory-installed with cover

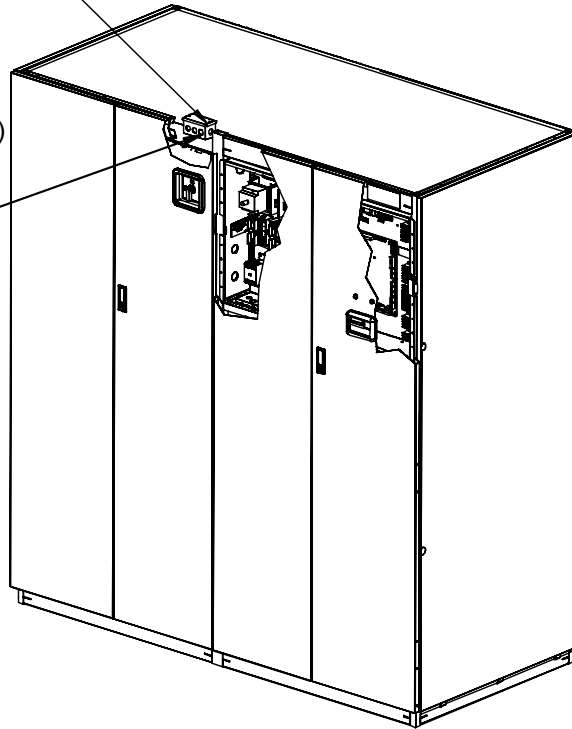

Figure 67 Liebert XDC electrical enclosure knockout locations for Extra Low Voltage connections

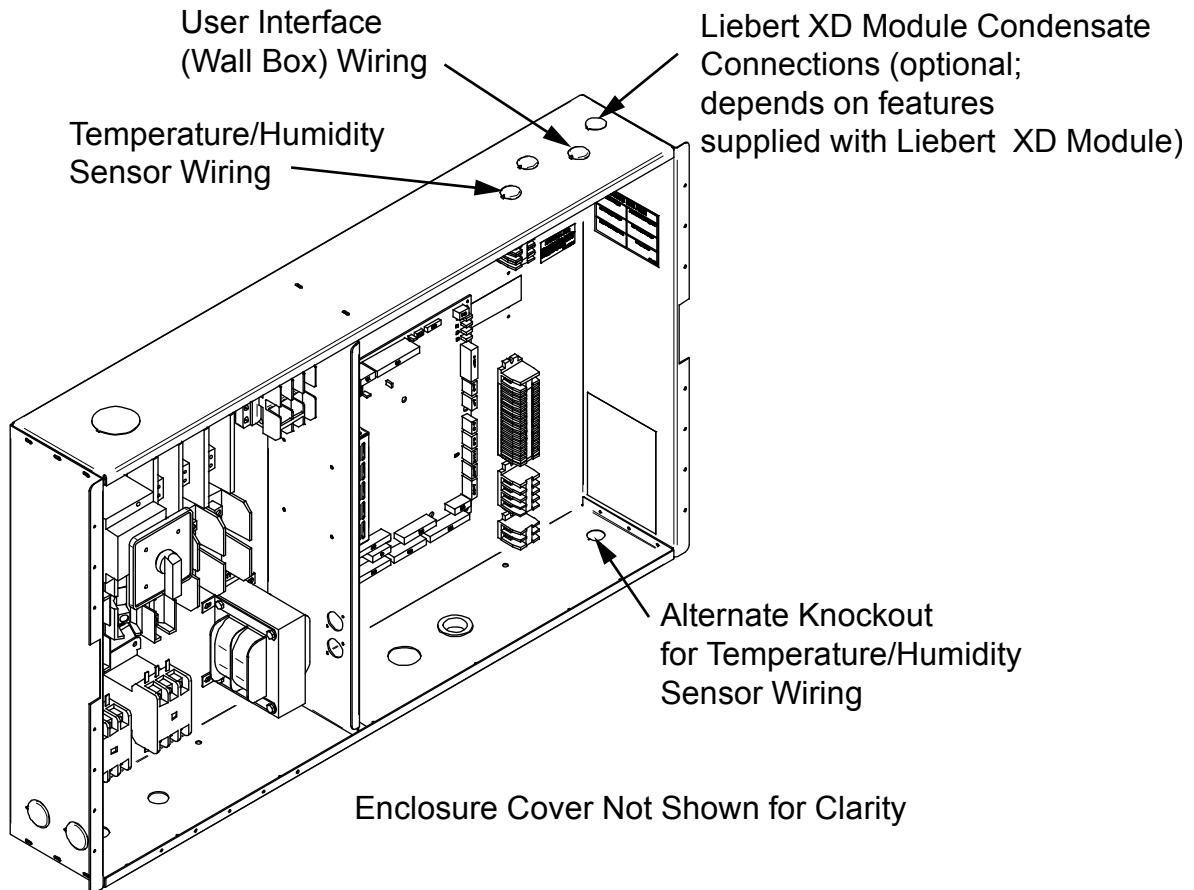
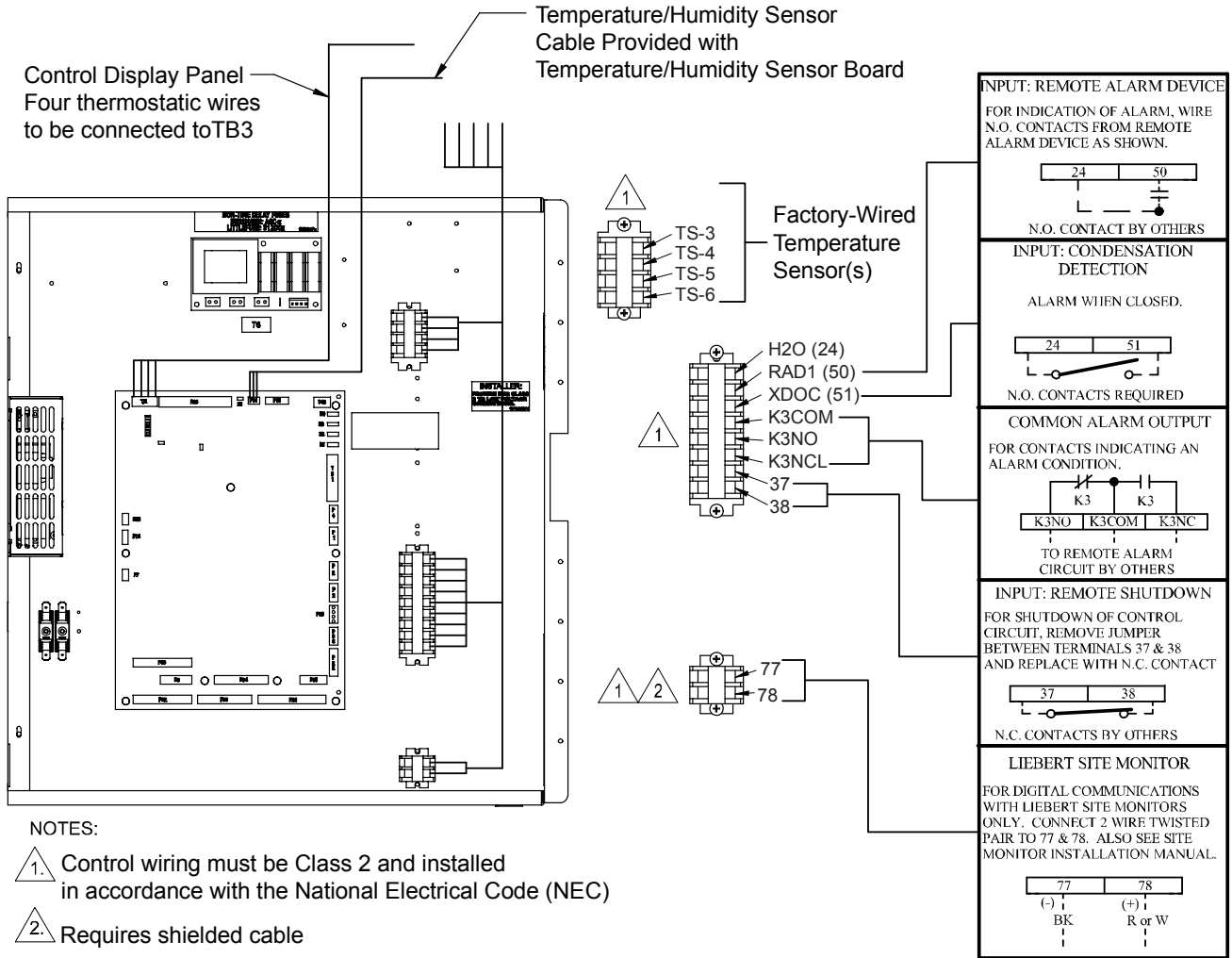

Figure 68 Liebert XDC Extra Low Voltage field connections points



5.0 SPECIFICATIONS

Table 27 Liebert XDC160 specifications

Models	XDC160 Air		XDC160 Water / Glycol
	XDC160AA	XDC160AM	189192G3 189192G5
Cooling Capacity, tons (kW)	46 (160)	37 (130)	See Tables 28, 29 and 30 for Water/Glycol performance data
Minimum Load	The Liebert XDC's minimum recommended operating load is 40% of system nominal capacity. For example, a Liebert XDC160 60Hz system's minimum load would be 64 kW. Loading below this value can unfavorably affect system operation. Consult factory for any loading below this recommendation.		
Electrical Requirements			
Input	460V-3ph-60Hz	380/415V-3ph-50Hz	460V-3ph-60Hz
Full Load Amps	79A		
Minimum supply wire sizing ampacity	84A		
Maximum fuse or circuit breaker size	100A		
Dimensions, inches (mm)			
Height - Main unit only	78 (1981)		
Height - Main unit only, as shipped	83 (2108)		
Width - Main unit	74 (1879)		
Depth - Main unit	34-5/8 (879)		
Height - Water / Glycol cooled condenser stand	N/A	24 (607)	
Width - Water / Glycol cooled condenser stand	N/A	72 (1829)	
Depth - Water / Glycol cooled condenser stand	N/A	33 (839)	
Weight, lb (kg)			
Main unit only	1800 (817)		
Main unit only, as shipped	Domestic: 1945 (882); Export: 2093 (949)		
Water / Glycol cooled condenser stand	N/A	1075 (488)	
Water / Glycol cooled condenser stand, as shipped	N/A	1150 (521)	
Pipe Connections, inches, O.D., Cu			
Liebert XD Coolant supply to XD cooling modules	1-1/8		
Liebert XD Coolant return from XD cooling modules	2-1/8		
Liquid line, DX circuit	7/8		
Hot gas line, DX circuit	1-3/8		
Heat Rejection Equipment			
95°F ambient air cooled condenser	1-CDL830 or 2-CSL415		N/A
Number of XD Cooling Units Connected, Maximum (Minimum)			
Liebert XDCF10	16 (6)		
Liebert XDH20	8 (4)		
Liebert XDH32	5 (2)		
Liebert XDO16	10 (4)		
Liebert XDO20	8 (4)		
Liebert XDV8	20 (8)		
Liebert XDV10	16 (7)		
Cabinet Exterior Finish	Black, matte finish, heat-fused powder coat		
Maximum Ambient Operating Temperature °F(°C)	86 (30)		
Agency			
Approvals	CSA	CE	CSA

Table 28 Floor stand specifications—water-cooled Liebert XDC

Models - 60 Hz	XDC160 Water Floor Stand - 60Hz				
Entering Fluid Temp °F (C)	65 (18)	70 (21)	75 (24)	85 (29)	95 (35)
Performance Data					
Cooling capacity, tons (kW)	46.1(162.3)	46.1(162.3)	46.1(162.3)	46.1(162.3)	44.5(156.5)
Flow, GPM	50	58	70	110	142
Pressure Drop, psi (Ft Water)	2.7 (6.2)	4.9 (11.3)	5.4 (12.5)	20.7 (47.8)	27.3 (63.1)
Heat Rejection Equipment					
Water regulating valve size	1"	1"	1"	1"	1"
Piping Connections					
Water / glycol supply and return lines	2-1/8"	2-1/8"	2-1/8"	2-1/8"	2-1/8"

Table 29 Floor stand specifications—Liebert XDC with 40% propylene glycol

Models - 60 Hz	XDC160 Glycol Floor Stand - 60Hz - 40% PG		
Outside Ambient °F (°C)	95 (35)	100 (38)	105 (41)
Entering Fluid Temp °F (°C)	110 (43)	110 (43)	110 (43)
Performance Data			
Cooling capacity, tons (kW)	42.5 (149.4)		
Total Heat Rejection, (kW)	192.6		
Flow, GPM	206		
Pressure Drop, psi (ft water)	37.2 (85.9)		
Heat Rejection Equipment			
Drycooler	DNT 940A		2 x DNT 880A*
Drycooler Pressure Drop, psi (ft water)	6.7 (15.5)		2.9 (6.6)
Glycol pump package - 10hp	9A31258G3		
Pump Control Package - 208V	9A34606G47		
Pump Control Package - 460V	9A32114G4		
Pump Total Head @ 204 GPM, ft water	145		
Water regulating valve size	1-1/4"		
Piping Connections			
Water / glycol supply and return lines	2-5/8"		

* When multiple drycoolers are used ensure flow is balanced.

Table 30 Floor stand specifications—Liebert XDC with 40% ethylene glycol

Models - 60 Hz	XDC160 Glycol Floor Stand - 60Hz - 40% EG		
Outside Ambient °F (°C)	95 (35)	100 (38)	105 (41)
Entering Fluid Temp °F (°C)	110 (43)	110 (43)	110 (43)
Performance Data			
Cooling capacity, tons (kW)	42.5 (149.4)		
Total Heat Rejection, (kW)	192.6		
Flow, GPM	204		
Pressure Drop, psi (ft water)	35.9 (82.9)		
Heat Rejection Equipment			
Drycooler	DNT 940A	2 x DNT 880A*	
Drycooler Pressure Drop, psi (ft water)	6.5 (15.1)	2.7 (6.3)	
Glycol pump package - 10HP	9A31258G3		
Pump Control Package - 208V	9A34606G47		
Pump Control Package - 460V	9A32114G4		
Pump Total Head @ 204 GPM, ft water	145		
Water regulating valve size	1-1/4"		
Piping Connections			
Water / glycol supply and return lines	2-5/8"		

* When multiple drycoolers are used ensure flow is balanced.

Table 31 Liebert XDP160 specifications

Models	XDP160RC	XDP160RA	XDP160RM
Cooling Capacity, Nominal	160 kW / 46 Tons, 60Hz		140 kW / 40 Tons, 50Hz
	Each capacity is based on 45°F (7°C) entering water temperature and 140gpm (530lpm) water flow rate. Capacity is reduced when glycol mixtures are used in place of 100% water.		
Minimum Load	The Liebert XDP's minimum recommended operating load is 20% of system nominal capacity. For example, a Liebert XDP160 60Hz system's minimum load would be 32 kW. Loading below this value can unfavorably affect system operation. Consult factory for any loading below this recommendation.		
Electrical Requirements			
Input	208V/3ph/60Hz	460V/3/ph60Hz	380/415V/3ph/50Hz
Full Load Amps	4A	2.1A	2.3A
Dimensions, inches (mm)			
Height – Unit only	78 (1981)		
Height – As shipped	83 (2108)		
Width	38 (965)		
Depth	34 (864)		
Weight, lb (kg)			
Unit only	821 (372)		
Shipping weight	Domestic: 990 (449); Export: 1067 (484)		
Installed, with refrigerant and chilled water	1038 (471)		
Pipe Connections			
Refrigerant supply to Liebert XD cooling module	1-1/8" OD, Cu		
Refrigerant return from Liebert XD cooling module	2-1/8" OD, Cu		
Chilled water supply and return	2-5/8" OD, Cu		
Control valve	2-way, 2" nominal; 35 PSIG close off pressure rating; 150 PSIG maximum allowable pressure		
Pressure Drop – Chilled Water Side	20 psig (137kPa, 1.38bar), with 140 gpm (530lpm) water flow rate, control valve fully open		
Temperature Rise – Chilled Water Side at rated flow, °F (°C)	8.0 (4.4)		6.9 (3.8)
Number of Liebert XD cooling units connected, maximum (minimum)			
Liebert XDCF10	16 (4)		
Liebert XDH20	8 (2)		
Liebert XDH32	5 (1)		
Liebert XDV8	20 (4)		
Liebert XDV10	16 (4)		
Liebert XDO16	10 (2)		
Liebert XDO20	8 (2)		
Cabinet Exterior Finish	Black, matte finish, heat-fused powder coat		
Operating Ambient Temperature, Maximum, °F (°C)	86 (30)		
Agency			
Approvals	CSA 60Hz		CE 50Hz

Table 32 Liebert XDO16 specifications

Models	XDO16BK--0 XDO16DK--0 XDO16BK-E0 XDO16DK-E0 XDO16BKP-0 XDO16BKPE0 XDO16DKP-0 XDO16DKPE0 (60Hz)	XDO16BSP-0 XDO16BSPE0 XDO16DSP-0 XDO16DSPE0 XDO16BS--0 XDO16DS--0 XDO16BS-E0 XDO16DS-E0 (60Hz)	XDO16BSP-0 XDO16BSPE0 XDO16DSP-0 XDO16DSPE0 XDO16BS--0 XDO16DS--0 XDO16BS-E0 XDO16DS-E0 (50Hz)
Cooling Capacity	Nominal (92°F [33°C] EAT): 17.2kW / 5 Tons Maximum (90°F [32°C] EAT): 17.2 kW / 5 Tons		Nominal (92°F [33°C] EAT): 17.1kW/4.9Tons Maximum (93°F [34°C] EAT): 17.2 kW / 5 Tons
Conditions	Capacity rating is @ 55°F (13°C) Entering Fluid Temperature and 50°F or lower dew point		
Electrical Requirements			
Input Voltage	1ph-60Hz-120V	1ph-50 Hz-220-240V	1ph-50 Hz-230V
Input Power Connections	Terminal blocks provided internal to unit		
Full Load Amps	2.7A @ 120V	1.50 @ 230V	1.19 @ 230V
Wire Size Amps	3.4	2.0	1.28
Overcurrent Protection Device	15	15	15
Power consumption, nominal, watts	335	250	250
Dimensions, inches (mm)			
Length	72-1/4 (1835)		
Width	24-1/8 (613)		
Height	22-1/2 (572) not including electrical and piping access		
Weight, lb (kg)			
Unit only	150 (68)		
Shipping weight	238 (108)	296 (134)	
Installed, with refrigerant, without options	155 (70)		
Number of Fans	1	1	
Airflow, Nominal, ft³/ min (m³/ hr)	2700 (4587)	2250 (3822)	
Audible Noise	85 dBA sound power	83 dBA sound power	
Pipe Connections			
Refrigerant Supply from Liebert XDP/Liebert XDC	1/2" OD, Copper		
Refrigerant Return to Liebert XDP/Liebert XDC	7/8" OD, Copper		
Serviceable Parts	Fan and electrical components		
Exterior Finish – Bottom, Sides, Front and Rear	Black, matte finish, heat-fused powder coat		
Exterior Finish - Top	Hot-dipped galvanized steel		
Agency			
Approvals	CSA 60 Hz	CSA 60Hz	CE 50Hz
Options			
Lighting Fixtures (ship loose)	2 Liebert XDOs per lighting unit; 120V or 277V; 4' standard fluorescent tubes (not included)		
Power, optional lighting fixture	0.9A per 120V light fixture; 0.4A per 277V light fixture	None	
Condensate sensing (factory-installed)	Dry contact 24VAC - 1A maximum		

Table 33 Liebert XDO20 specifications

Models	XDO20DK--*; XDO20BKP-* XDO20DKP-*; XDO20BK-E* XDO20DK-E*; XDO20BKPE* XDO20DKPE*	XDO20BS--*; XDO20DS--* XDO20BSP-*; XDO20DSP-v XDO20BS-E*; XDO20DS-E* XDO20BSPE*; XDO20DSPE*	
	60Hz	60Hz	50Hz
Cooling Capacity	Nominal (92°F [33°C] EAT): 20kW / 5.7 Tons Maximum (100°F [38°C] EAT): 23kW / 6.5 Tons		Nominal (92°F [33°C] EAT): 17.7kW / 5 Tons Maximum (103°F [39°C] EAT): 23kW / 6.5 Tons
Conditions	Capacity rating is @ 55°F (13°C) Entering Fluid Temperature and 50°F (10°C) or lower dew point		
Electrical Requirements			
Input Voltage	1ph-60Hz-120V	1ph-60Hz-220-240V	1ph-50 Hz-220-240V
Input Power Connections	Terminal blocks provided internal to unit		
Full Load Amps	2.7A @ 120V	1.64A @ 230V	1.47 @ 230V
Wire Size Amps	3.4	2.0	1.84
Overcurrent Protection Device	15	15	15
Power consumption, nominal, watts	335	350	250
Dimensions, inches (mm)			
Length	72-1/4 (1835)		
Width	24-1/8 (613)		
Height	22-1/2 (572) not including electrical and piping access		
Weight, lb (kg)			
Unit only	150 (68)		
Shipping weight	238 (108)	296 (134)	
Installed, with refrigerant, without options	155 (70)		
Number of Fans	1		1
Airflow, Nominal, ft³/ min (m³/ hr)	2700 (4587)		2250 (3822)
Audible Noise	85 dBa sound power		83 dBa sound power
Pipe Connections (without flex pipe)			
Refrigerant Supply from Liebert XDP/Liebert XDC	1/2" OD, Copper		
Refrigerant Return to Liebert XDP/Liebert XDC	7/8" OD, Copper		
Serviceable Parts	Fan and electrical components		
Exterior Finish – Bottom, Sides, Front and Rear	Black matte finish, heat-fused powder coat		
Exterior Finish - Top	Hot-dipped galvanized steel		
Agency			
Approvals	CSA 60 Hz		CE 50Hz
Options			
Lighting Fixtures (ship loose)	2 Liebert XDOs per lighting unit; 120V or 277V; 4' standard fluorescent tubes (not included)		
Power, optional lighting fixture	0.9A per 120V light fixture; 0.4A per 277V light fixture		None
Condensate sensing (factory-installed)	Dry contact 24VAC - 1A maximum		
Pre-Charged Refrigerant	R-134a Refrigerant, one-shot connections		

* = Revision level

Table 34 Liebert XDO20 dimensions—domestic and export

Model	Shipping Dimensions, inches (mm)						Unit Dimension Unpacked, inches (mm)		
	Domestic			Export			Length	Width	Height *
	Length	Width	Height	Length	Width	Height			
All Models	84 (2134)	30 (762)	30 (762)	83 (2108)	30 (762)	30 (762)	72-1/4 (1835)	24-1/8 (613)	25-1/2 (648)

* Includes piping connections

Table 35 Liebert XDO16 dimensions—domestic and export

Model	Shipping Dimensions, inches (mm)						Unit Dimension Unpacked, inches (mm)		
	Domestic			Export			Length	Width	Height *
	Length	Width	Height	Length	Width	Height			
All Models	84 (2134)	30 (762)	30 (762)	83 (2108)	30 (762)	30 (762)	72-1/4 (1835)	24-1/8 (613)	25-1/2 (648)

* Includes piping connections

Table 36 Liebert XDV8 specifications

Models	XDV8BK--*; XDV8DK--* XDV8BKP-*; XDV8DKP-* XDV8BK-E*; XDV8DK-E* XDV8BKPE*; XDV8DKPE* XDV8BKR-*; XDV8BKRE* XDV8DKR-*; XDV8DKRE*	XDV8BT--*; XDV8DT--* XDV8BTP-*; XDV8DTP-* XDV8BT-E*; XDV8DT-E* XDV8BTPE*; XDV8DTPE* XDV8BTR-*; XDV8BTRE* XDV8DTR-*; XDV8DTRE*	XDV8BS--*; XDV8DS--* XDV8BSP-*; XDV8DSP-* XDV8BS-E*; XDV8DS-E* XDV8BSPE*; XDV8DSPE* XDV8BSR-*; XDV8BSRE* XDV8DSR-*; XDV8DSRE*	
	60 Hz	60 Hz	50 Hz	50 Hz
Cooling Capacity	Nominal (98°F [37°C] EAT): 8.8kW / 2.5 Tons Maximum (95°F [35°C] EAT): 8.8kW / 2.5 Tons		Nominal (98°F [37°C] EAT): 8kW/2.3 Tons Maximum (103°F [39°C] EAT): 8.8kW/2.5Tons	
Conditions	Capacity rating is @ 55°F (13°C) Entering Fluid Temperature and 50°F (10°C) or lower dew point, rear air inlet.			
Electrical Requirements				
Input	120V model: 1ph-60 Hz	230V model: 1ph-60 Hz	230V model: 1ph-50 Hz	
Input power connections	2 power connections, each model			
Full Load Amps	120V model: 2.0A	230V model: 1.0A		
Power consumption, nominal, watts	180	190	190	190
Dimensions, inches (mm)				
Height – unit only	14 (355) not including pipe connections			
Height – including pipe connections	18-5/8 (473)			
Width	22-7/8 (581)			
Depth – Top	39-1/2 (1003)			
Depth – Bottom	29-5/8 (752)			
Weight, lb (kg)				
Unit only	77 (35)			
Shipping weight	125 (57)			
Installed, with refrigerant	79 (36)			
Number of Fans	2	2	2	2
Airflow, Nominal, ft³/ min (m³/ hr)	1000 (1699) with rear inlet. Bottom inlet airflow may be less, depending on restrictions inside cabinet		833 (1415) with rear inlet. Bottom inlet airflow may be less, depending on restrictions inside cabinet	
Audible noise	78 dBa sound power		73 dBa sound power	
Pipe Connections (without Liebert Flex Pipe)				
Refrigerant Supply from Liebert XDP/Liebert XDC	1/2" OD Cu, (optional 1/2" threaded coupler flex piping)			
Refrigerant Return to Liebert XDP/Liebert XDC	5/8" OD Cu, (optional 3/4" threaded coupler flex piping)			
Serviceable Parts	Fans and electrical components			
Cabinet Exterior Finish	Black, matte finish, heat-fused powder coat			
Options				
Condensate sensing (factory-installed)	Dry contact outgoing signal			
Pre-Charged	R-134a Refrigerant, one-shot connections			
Agency				
Approvals	CSA 60Hz	CSA 50Hz	CE 50Hz	

* = Revision level of unit

Table 37 Liebert XDV10 specifications

Models	XDV10BK--*; XDV10DK--* XDV10BKP--*; XDV10DKP--* XDV10BK-E*; XDV10DK-E* XDV10BKPE*; XDV10DKPE* XDV10BKR--*; XDV10BKRE* XDV10DKR--*; XDV10DKRE*	XDV10BT--*; XDV10DT--* XDV10BTP--*; XDV10DTP--* XDV10BT-E*; XDV10DT-E* XDV10BTPE*; XDV10DTPE* XDV10BTR--*; XDV10BTRE* XDV10DTR--*; XDV10DTRE*	XDV10BS--*; XDV10DS--* XDV10BSP--*; XDV10DSP--* XDV10BS-E*; XDV10DS-E* XDV10BSPE*; XDV10DSPE* XDV10BSR--*; XDV10BSRE* XDV10DSR--*; XDV10DSRE*	
	60 Hz	60 Hz	50 Hz	50 Hz
Cooling Capacity	Nominal (98°F [37°C] EAT): 10kW / 2.8 Tons Maximum (106°F [41°C] EAT): 11.8kW/3.4 Tons		Nominal (98°F [37°C] EAT): 8kW / 2.3 Tons Maximum (116°F [47°C] EAT): 11.8kW/3.4 Tons	
Conditions	Capacity Rating is @ 55°F (13°C) Entering Fluid Temperature and 50°F (10°C) or lower dew point, rear air inlet.			
Electrical Requirements				
Input	120V model: 1ph-60 Hz	230V model: 1ph-60 Hz	230V model: 1ph-50 Hz	
Input power connections	2 power connections, each model			
Full Load Amps	120V model: 2.0A	230V model: 1.0A		
Power consumption, nominal, watts	180	190	190	190
Dimensions, inches (mm)				
Height – unit only	14 (355) not including pipe connections			
Height – including hard pipe connections	18-5/8 (473)			
Height – including one-shot connections	19-5/8 (498)			
Width	22-7/8 (581)			
Depth – Top	39-1/2 (1003)			
Depth – Bottom	29-5/8 (752)			
Weight, lb (kg)				
Unit only	77 (35)			
Shipping weight	125 (57)			
Installed, with refrigerant	79 (36)			
Number of fans	2	2	2	2
Airflow, Nominal, ft³/ min (m³/ hr)	1000 (1699) with rear inlet. Bottom inlet airflow may be less, depending on restrictions inside cabinet		833 (1415) with rear inlet. Bottom inlet airflow may be less, depending on restrictions inside cabinet	
Audible noise	78 dBA sound power		73 dBA sound power	
Pipe Connections (without Liebert Flex Pipe)				
Refrigerant supply from Liebert XDP/ XDC	1/2" OD, Cu, (optional 1/2" threaded coupler flex piping)			
Refrigerant return to Liebert XDP/ XDC	5/8" OD, Cu, (optional 3/4" threaded coupler flex piping)			
Serviceable Parts	Fans and electrical components			
Cabinet Exterior Finish	Black, matte finish, heat-fused powder coat			
Options				
Condensate sensing (factory-installed)	Dry contact outgoing signal			
Pre-Charged Refrigerant	R-134a Refrigerant, one-shot connections			
Agency				
Approvals	CSA 60Hz	CSA 50Hz	CE 50Hz	

* = Revision level of unit

Table 38 Liebert XDV8 dimensions—domestic and export

Model	Shipping Dimensions Length x Width x Height inches (mm)		Unit Dimensions Unpacked Length x Width x Height inches (mm)
	Domestic	Export	Unit Only
All Models	48 x 40 x 24-1/4 (1219 x 1016 x 616)	45-4/5 x 30-3/4 x 33 (1163 x 781 x 839mm)	39-1/2 x 22-7/8 x 14 (1003 x 581 x 356)

Table 39 Liebert XDV10 dimensions—domestic and export

Model	Shipping Dimensions Length x Width x Height inches (mm)		Unit Dimensions Unpacked Length x Width x Height inches (mm)
	Domestic	Export	Unit Only
All Models	48 x 40 x 24-1/4 (1219 x 1016 x 616)	45-4/5 x 30-3/4 x 33 (1163 x 781 x 839mm)	39-1/2 x 22-7/8 x 14 (1003 x 581 x 356)

Table 40 Liebert XDCF specifications

Models	XD-CF-10-TP-0, XD-CF-10-TPE-0 XD-CF Top EXP, XD-CF-10-BPE-0 XD-CF BTM EXP, XD-CF-10-BP-0	
Cooling capacity, maximum	10kWH / 2.8 Tons / 34,000 BTUh	
Conditions	55°F (13°C) entering fluid temperature, 50°F (10°C) or lower dew point	
Dimensions, inches (mm)		
Height – including pipe connections	31-3/8" (797mm)	
Width	13-7/16" (341mm)	
Depth	7-5/16" (186mm)	
Weight, lb (kg)		
Unit only	18 (8.2)	
Shipping weight	30 lb. (13.06 kg)	
Pipe connections		
Refrigerant Supply from Liebert XDP/Liebert XDC	1/2" threaded one-shot coupling on the unit	
Refrigerant Return to Liebert XDP/Liebert XDC	5/8" threaded one-shot coupling on the unit	
Cabinet exterior finish	Gray	
Agency		
Safety	CSA — CE	

Table 41 Liebert XDH specifications

Models	XDH20DKP-0 XDH20DK--0 XDH20BKP-0 XDH20BK--0 XDH20DKPE0 XDH20DK-E0 XDH20BKPE0 XDH20BK-E0 (60Hz)	XDH32DKP-0 XDH32DK--0 XDH32BKP-0 XDH32BK--0 XDH32DKPE0 XDH32DK-E0 XDH32BKPE0 XDH32BK-E0 (60Hz)	XDH20DSP-0 XDH20DS--0 XDH20BSP-0 XDH20BS--0 XDH20DSPE0 XDH20DS-E0 XDH20BSPE0 XDH20BS-E0 (50/60Hz)	XDH32DSP-0 XDH32DS--0 XDH32BSP-0 XDH32BS--0 XDH32DSPE0 XDH32DS-E0 XDH32BSPE0 XDH32BS-E0 (50/60Hz)
Cooling Capacity	XDH20, 60Hz Nominal (98°F [37°C] EAT): 22kW/6.3 Tons XDH20, 60Hz Maximum (105°F [40°C] EAT): 25.5kW/7.3 Tons XDH20, 50Hz Nominal (98°F [37°C] EAT): 19kW / 5.4 Tons XDH20, 50Hz Maximum (116°F [47°C] EAT): 25.5kW/7.3 Tons XDH32, 60Hz Nominal (98°F [37°C] EAT): 30kW/8.5 Tons XDH32, 60Hz Maximum (105°F [40°C] EAT): 34.5kW/7.3 Tons XDH32, 50Hz Nominal (98°F [37°C] EAT): 27kW / 7.7 Tons XDH32, 50Hz Maximum (108°F [42°C] EAT): 34.5kW/7.3 Tons			
Conditions	Capacity rating is @ 55°F (13°C) Entering Fluid Temperature and 50°F (10°C) or lower dew point			
Electrical Requirements				
Input	120V-1ph-60Hz		220-240V-1ph-50Hz, CE / 208-240V-1ph-60Hz, CSA	
Input Power Connections	Two IEC320-C14 power inlets and two IEC power cords with NEMA 5-15P connectors		Two IEC320-C14 power inlets and two IEC power cords with IEC320-C14 receptacles	
Full Load Amps	5	10	2.5	5
Power Consumption, Nominal, Watts	600	1200	575	1150
Dimensions, inches (mm)				
Height—Unit Only	78 (1981)			
Height—Including Pipe Connections	80 (2032)			
Width	12 (305)			
Depth	42 (1067)			
Weight, lb (kg)				
Unit Only	233 (106)	246 (112)	233 (106)	246 (112)
Shipping Weight	317 (144)	330 (150)	317 (144)	330 (150)
Number of Fans	6			
Airflow, Nominal, ft³/min (m³/hr)	2500 (4248)	4000 (6796)	2428 (4125)	3850 (6541)
Audible Noise, Sound Power	81 dBa	86 dBa	81 dBa	86 dBa
Pipe Connections				
Refrigerant Supply	1/2" OD, Cu (optional 1/2" threaded one-shot coupling on the unit)			
Refrigerant Return	7/8" OD, Cu (optional 7/8" threaded one-shot coupling on the unit)			
Serviceable Parts	Fans and electrical components			
Cabinet Exterior Finish	Black, matte finish, heat-fused powder coat			
Options	Condensate Sensing (factory-installed) Dry contact outgoing signal (24VAC - 1A maximum)			
	One-shot style flex pipe connections			
	Uni-directional or bi-directional air diffusers			
Agency				
Approvals	CSA 60Hz		CE 50Hz, CSA 50/60Hz	

Notes

Ensuring The High Availability Of Mission-Critical Data And Applications.

Emerson Network Power, the global leader in enabling business-critical continuity, ensures network resiliency and adaptability through a family of technologies—including Liebert power and cooling technologies—that protect and support business-critical systems. Liebert solutions employ an adaptive architecture that responds to changes in criticality, density and capacity. Enterprises benefit from greater IT system availability, operational flexibility and reduced capital equipment and operating costs.

Technical Support / Service Web Site

www.liebert.com

Monitoring

800-222-5877

monitoring@emersonnetworkpower.com

Outside the US: 614-841-6755

Single-Phase UPS

800-222-5877

upstech@emersonnetworkpower.com

Outside the US: 614-841-6755

Three-Phase UPS

800-543-2378

powertech@emersonnetworkpower.com

Environmental Systems

800-543-2778

Outside the United States

614-888-0246

Locations

United States

1050 Dearborn Drive

P.O. Box 29186

Columbus, OH 43229

Europe

Via Leonardo Da Vinci 8

Zona Industriale Tognana

35028 Piove Di Sacco (PD) Italy

+39 049 9719 111

Fax: +39 049 5841 257

Asia

7/F, Dah Sing Financial Centre

108 Gloucester Road, Wanchai

Hong Kong

852 2572220

Fax: 852 28029250

While every precaution has been taken to ensure the accuracy and completeness of this literature, Liebert Corporation assumes no responsibility and disclaims all liability for damages resulting from use of this information or for any errors or omissions.

© 2007 Liebert Corporation

All rights reserved throughout the world. Specifications subject to change without notice.

® Liebert is a registered trademark of Liebert Corporation.

All names referred to are trademarks

or registered trademarks of their respective owners.

SL-16655_REV08_06-08

Emerson Network Power.

The global leader in enabling *Business-Critical Continuity*.

■ AC Power

■ Embedded Computing

■ Outside Plant

■ Racks & Integrated Cabinets

■ Connectivity

■ Embedded Power

■ Power Switching & Controls

■ Services

■ DC Power

■ Monitoring

■ Precision Cooling

■ Surge Protection

EmersonNetworkPower.com

Business-Critical Continuity, Emerson Network Power and the Emerson Network Power logo are trademarks and service marks of Emerson Electric Co.

©2007 Emerson Electric Co.